



- The right angle drill attachment enables drilling of holes where no other conventional drill will fit.
- Fits to any drill with 10 mm or larger capacity chuck.
- The right angle drill attachment is equipped with a 3/8" x 24 threaded mount and can be supplied:
  - 1) Without chuck code RADA
  - 2) With key type chuck code RADACK
  - 3) With keyless chuck code RADACL
- Double heat treated helical gear.
- Aluminum alloy metal housing industrial quality guaranteed.
- Gear ratio 1:1,3
- Max drilling capacity:
  - 10 mm in steel
  - 16 mm in wood.
- Maximum speed: 2.100 rpm.
- Max torque: 29,4 Nm.

Model No.	Packaging style	Weight g
RADA	Individual box	310
RADAB	Blister card	



**RADA**

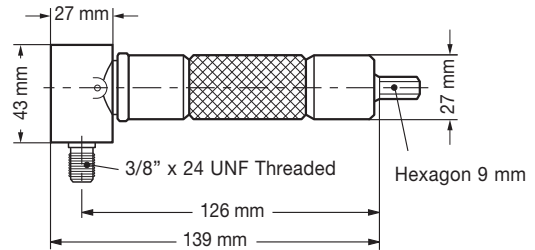

This model for screw driving applications only. It's equipped with magnetic hexagon hole to insert screwing bits.

Model No.	Packaging style	Weight g
RADAX	Individual box	315
RADAXB	Blister card	



**RADAX**

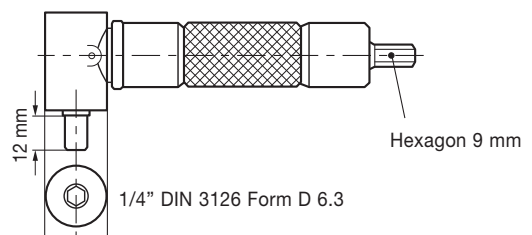

Model No.	Packaging style	Weight g
RADAV	Individual box	315
RADAVB	Blister card	



**RADAV**

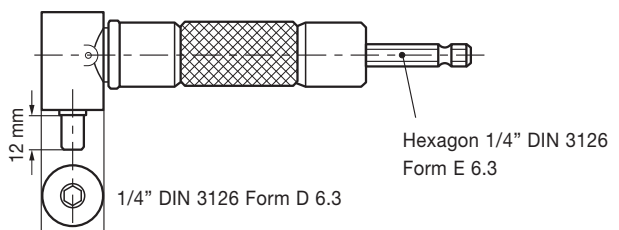

	Model No.	Packaging style	Weight g
 <p><b>RADACK</b></p>	RADACK	Individual box	455

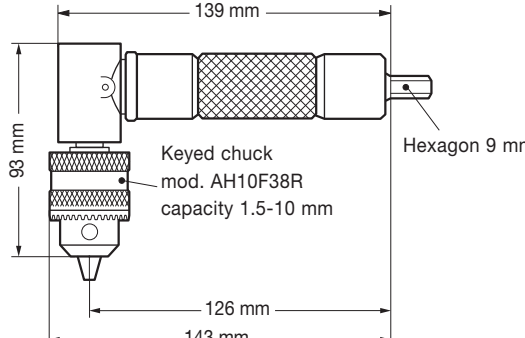

	Model No.	Packaging style	Weight g
 <p><b>RADACL</b></p>	RADACL	Individual box	490

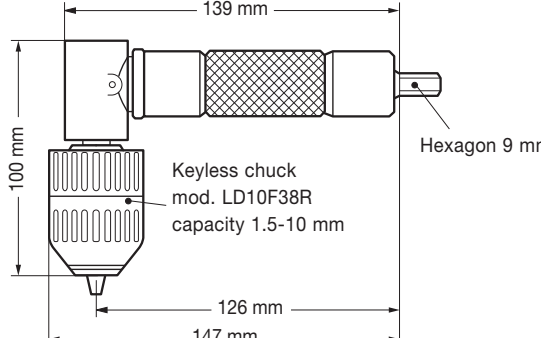

### Spare parts

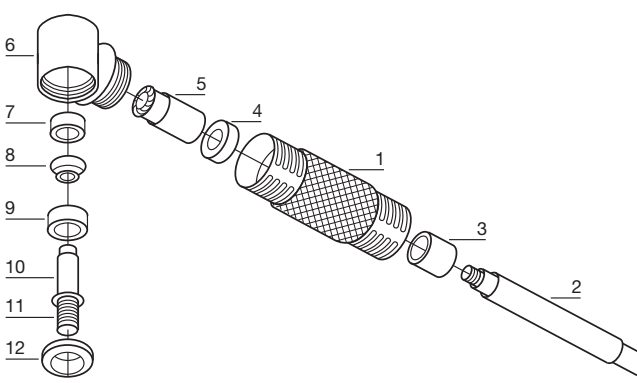

Model No.	Item No.	Description	Quantity
XRADA01	1	Body with bushing	1
XRADA02	2	Clutch pin	1
XRADA03	3	Needle bearing	1
XRADA04	4	Ball bearing	1
XRADA05	5	Bevel gear pin	1
XRADA06	6	Angle head	1
XRADA07	7	Ball bearing	1
XRADA08	8	Bevel gear	1
XRADA09	9	Ball bearing	1
XRADA10	10	Key	1
XRADA11	11	Chuck casing	1
XRADA12	12	Bearing cap	1



Model No.	Packaging style	Weight g
RADAQXPRO	Individual box	689

Heavy duty Professional RADA with quick release bit holder (9H) and handle.  
 MAX Torque 100 N.m.  
 Gear Ratio: 1:1.28  
 Code: RADAQXPRO



Model No.	Packaging style	Weight g
RADAPRO	Individual box	670

Heavy duty Professional RADA with 3/8" x 24 threaded head to fasten a chuck and handle.  
 MAX Torque 100 N.m.  
 Gear Ratio: 1:1.28  
 Code: RADAPRO

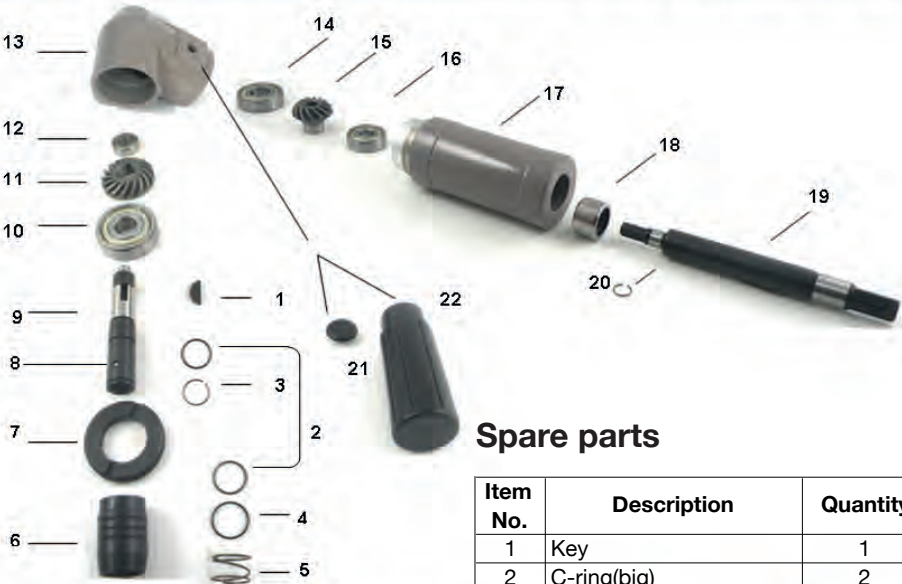

**Spare parts**

Item No.	Description	Quantity	Item No.	Description	Quantity
1	Key	1	12	Bearing	1
2	C-ring(big)	2	13	Angle Head	1
3	C-ring(mid)	1	14	Bearing	1
4	Washer	1	15	Gear	1
5	Spring	1	16	Bearing	1
6	Shell of quick release	1	17	Body With Bushing	1
7	Bearing Cap	1	18	Bearing	1
8	Ball	2	19	Clutch Pin	1
9	Chuck Casing	1	20	C-ring(small)	1
10	Bearing	1	21	Dust plug	3
11	Gear	1	22	Handle	1

## 360° right angle drill attachment

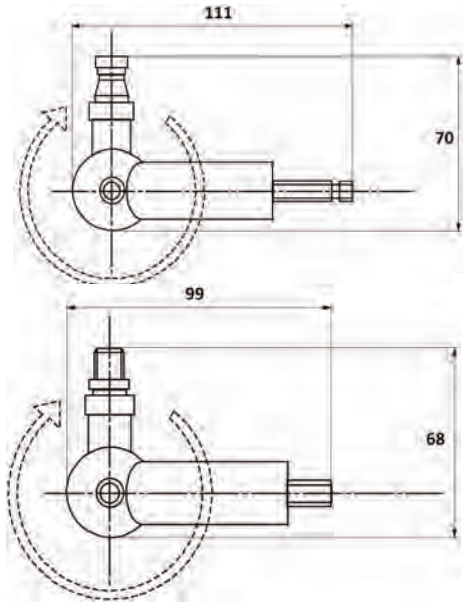

- This right angle drill attachment with a 360° full rotation enables drilling of holes and screwdriving where no other conventional drill will fit.
- It can be fitted on all standard power tools and screwdrivers.
- A T Key wrench available in the package can lock the tool at the desired angle.

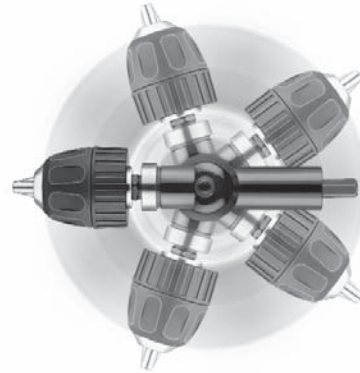

### ON DRILLING POWER TOOLS

- max. speed: 3500 rpm
- max torque: 35 Nm

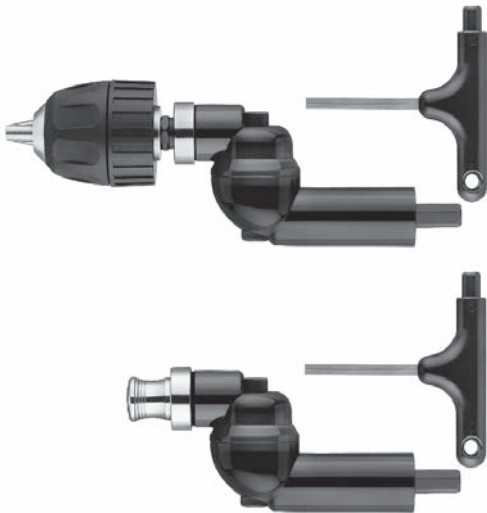

#### DRILLING HOLES

Mod. **RADA360CL**  
With a keyless chuck mod. LD10F38R  
cap. 1.5-10 mm

Packaging style: individual box  
Weight g: 465

#### SCREWDRIVING

Mod. **RADAQ360**  
With a quick change chuck for bits

Packaging style: individual box  
Weight g: 301

### ON SCREWDRIVERS

- max. speed: 3500 rpm
- max torque: 35 Nm

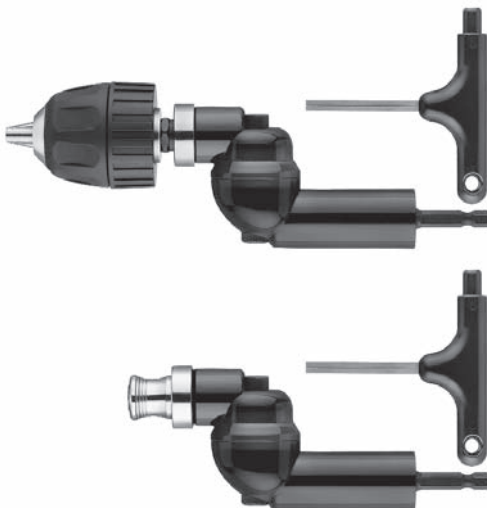

#### DRILLING HOLES

Mod. **RDAV360CL**  
With a keyless chuck mod. LD10F38R  
cap. 1.5-10 mm

Packaging style: individual box  
Weight g: 465

#### SCREWDRIVING

Mod. **RADAQV360**  
With a quick change chuck for bits

Packaging style: individual box  
Weight g: 301