



Porta

CATALOGUE 2024

DRILL CHUCKS & POWER TOOL ACCESSORIES

SINCE 1936

WWW.PORTACHUCKS.COM

INDICE

KEYLESS DRILL CHUCKS

INDUSTRIAL LINE

VALIDUS KEYLESS CHUCKS	1
------------------------------	---

INDUSTRIAL - PK LINE

VALIDUS-PK KEYLESS CHUCKS	2
---------------------------------	---

PRECISION INDUSTRIAL LINE

SUPER VALIDUS KEYLESS CHUCKS	2
------------------------------------	---

HIGH PRECISION INDUSTRIAL LINE

HIGH PRECISION SELF-TIGHTENING KEYLESS CHUCK - STANDARD	3
---	---

HIGH PRECISION SELF-TIGHTENING KEYLESS CHUCK - TITANIUS	3
---	---

PORTA PRECISION GRADE KEYLESS CHUCKS	4
--	---

PORTA PRECISION GRADE SPARE CHUCKS	4
--	---

PORTA PRECISION GRADE KEYLESS CHUCKS	5
--	---

REVERSING KEYLESS CHUCKS

TAURUS LINE

TAURUS RANGE KEYLESS CHUCK	6
----------------------------------	---

DIY DESIGN KEYLESS CHUCK - HEX SHANK QUICK CHANGE	6
---	---

TAURUS PROFESSIONAL LINE

TAURUS RANGE KEYLESS CHUCK	7
----------------------------------	---

TAURUS SUPER LINE

TAURUS SUPER CHUCKS	8
---------------------------	---

TAURUS SUPER - SPINDLE LOCK SYSTEM	9
--	---

TAURUS ULTIMATE LINE

TAURUS ULTIMATE CHUCKS	10
------------------------------	----

ULTIMATE SPINDLE-LOCK CHUCKS	10
------------------------------------	----

IMPACT CHUCK	11
--------------------	----

KEY OPERATED DRILL CHUCK

INDUSTRIAL LINE

KEY OPERATED CHUCKS	12
---------------------------	----

STANDARD LINE

STANDARD DUTY KEY OPERATED CHUCKS	13
---	----

KEY OPERATED CHUCKS FOR SCREWDRIVERS	13
--	----

NICKEL PLATED CHUCK	14
---------------------------	----

STAINLESS STEEL CHUCK	14
-----------------------------	----

PRECISION LINE

BALL BEARING DRILL CHUCK WITH KEY	14
---	----

KEYS

CHUCK KEYS	15
------------------	----

MACHINE TOOLS ACCESSORIES

ACCESSORIES

MORSE TAPER EJECTING DRIFTS	16
-----------------------------------	----

SEMI-AUTOMATIC EXTRACTORS	16
---------------------------------	----

EXTRACTOR FOR ACCESSORY SPINDLES	16
--	----

NAIL ATTACHMENT	16
-----------------------	----

RIGHT ANGLE DRILL ATTACHMENT	17
------------------------------------	----

RIGHT ANGLE DRILL ATTACHMENT - CONT.	18
---	----

PROFESSIONAL RIGHT ANGLE DRILL ATTACHMENT	19
---	----

360° RIGHT ANGLE DRILL ATTACHMENT	20
---	----

QUICK CHANGE SDS CONVERTER	21
----------------------------------	----

DRILLING AND SCREWING BITS	21
----------------------------------	----

RIVET CONVERTER	22
-----------------------	----

CHUCK EXTENDER FOR PORTABLE DRILL	22
---	----

FLEXIBLE BIT HOLDER FOR SCREWDRIVER	23
---	----

FLEXIBLE SHAFT WITH SPRING CHUCK	23
--	----

QUICK CLAMPING NUT	23
--------------------------	----

CHUCK ADAPTORS	24
----------------------	----

QUICK RELEASE 1/4" HEXAGON BIT HOLDERS	25
--	----

ARBORS

MORSE TAPER ARBORS	26
MORSE TAPER ARBORS - CONT	27
ISO TAPER ARBORS	27
PARALLEL ARBORS	28
BRIDGEPORT R8 TAPER ADAPTORS	28
BRIDGEPORT R8 TAPER ADAPTORS	28

SLEEVES

REDUCING SLEEVES	29
OIL TOUGHENED REDUCING SLEEVES	29
REDUCING SLEEVES WITH THROUGH HOLE	30
MORSE TAPER TURRET SOCKETS	30
ISO TAPER SLEEVES	31

SOCKETS

EXTENSION SOCKETS	31
OIL TOUGHENED EXTENSION SOCKETS	32
OIL TOUGHENED LONG PATTERN EXTENSION SOCKETS	32

LATHE CENTRES

LATHE (DEAD) CENTRES PRECISION GROUND	33
LATHE CENTRES PRECISION GROUND	34

REVOLVING CENTRES

REVOLVING CENTRES	35
COPY REVOLVING CENTRE	36

TECHNICAL INFORMATION

TECHNICAL INFORMATION	37
NOTE	40

VALIDUS KEYLESS CHUCKS

Self-tightening style for power tools, pedestal and bench drilling machines.
Rotary right hand rotation only.

INDUSTRIAL LINE

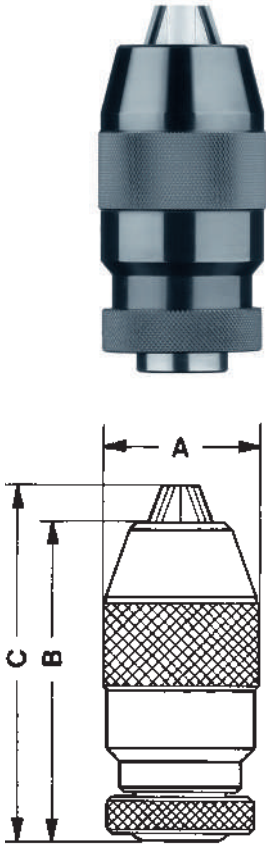

Model No	Drilling capacity mm	Mount	A mm	B mm	C mm	Packaging Style	Weight g
32B10	0-6	DIN B10	34,5	65	72	Individual box	365
32B12	0-6	DIN B12	34,5	65	72	Individual box	365
32J1	0-6	JACOBS 1	34,5	65	72	Individual box	365
32F38	0-6	Female thr. 3/8" x 24	34,5	65	72	Individual box	365
32F12	0-6	Female thr. 1/2" x 20	34,5	65	72	Individual box	365
34B10	0-8	DIN B10	34,5	65	72	Individual box	365
34B12	0-8	DIN B12	34,5	65	72	Individual box	365
34J2	0-8	JACOBS 2	34,5	65	72	Individual box	365
34J1	0-8	JACOBS 1	34,5	65	72	Individual box	365
34F38	0-8	Female thr. 3/8" x 24	34,5	65	72	Individual box	365
34F12	0-8	Female thr. 1/2" x 20	34,5	65	72	Individual box	365
35B12	1-10	DIN B12	34,5	72	79	Individual box	365
35J2	1-10	JACOBS 2	34,5	72	79	Individual box	365
35F38	1-10	Female thr. 3/8" x 24	34,5	72	79	Individual box	365
35F38B	1-10	Female thr. 3/8" x 24	34,5	72	79	Blister card	365
35F12	1-10	Female thr. 1/2" x 20	34,5	72	79	Individual box	365
35F12B	1-10	Female thr. 1/2" x 20	34,5	72	79	Blister card	365
36B16	0-10	DIN B16	44	83	93	Individual box	650
36J2	0-10	JACOBS 2	44	83	93	Individual box	650
36J33	0-10	JACOBS 33	44	83	93	Individual box	650
375B16	1.5-13	DIN B16	40,5	85	93	Individual box	540
375F38	1.5-13	Female thr. 3/8" x 24	40,5	85	93	Individual box	540
375F38B	1.5-13	Female thr. 3/8" x 24	40,5	85	93	Blister card	540
375F12	1.5-13	Female thr. 1/2" x 20	40,5	85	93	Individual box	540
375F12B	1.5-13	Female thr. 1/2" x 20	40,5	85	93	Blister card	540
37B12	1-13	DIN B12	42,5	90	101	Individual box	660
37B16	1.5-13	DIN B16	42,5	90	101	Individual box	660
37J6	1.5-13	JACOBS 6	42,5	90	101	Individual box	660
37J2	1.5-13	JACOBS 2	42,5	90	101	Individual box	660
37J33	1.5-13	JACOBS 33	42,5	90	101	Individual box	660
37F38	1.5-13	Female thr. 3/8" x 24	42,5	90	101	Individual box	660
37F12	1.5-13	Female thr. 1/2" x 20	42,5	90	101	Individual box	660
38B16	0-13	DIN B16	51	92,5	104	Individual box	1010
38J6	0-13	JACOBS 6	51	92,5	104	Individual box	1010
40B16	3-16	DIN B16	50,5	98	110	Individual box	1060
40B18	0-13	DIN B18	50,5	98	110	Individual box	1060
40J6	0-13	JACOBS 6	50,5	98	110	Individual box	1060
40J3	0-13	JACOBS 3	50,5	98	110	Individual box	1060
40F12	0-13	Female thr. 1/2" x 20	50,5	98	110	Individual box	1060
40F58	0-13	Female thr. 5/8" x 16	50,5	98	110	Individual box	1060
50B22	5-20	B22	57	116	129	Individual box	1525
50J3	5-20	JACOBS 3	57	116	129	Individual box	1525

VALIDUS-PK KEYLESS CHUCKS

Self-tightening style with a locking action ring suitable for percussion power tools. Rotary right hand rotation only.

INDUSTRIAL - PK LINE



<i>Model No</i>	<i>Drilling capacity mm</i>	<i>Mount</i>	<i>A mm</i>	<i>B mm</i>	<i>C mm</i>	<i>Packaging style</i>	<i>Weight g</i>
37PKF38	1-13	Female thr. 3/8" x 24	43	86	100	Individual box	690
37PKF12	1-13	Female thr. 1/2" x 20	43	86	100	Individual box	680

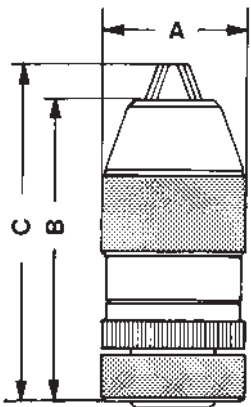

SUPER VALIDUS KEYLESS CHUCKS

For machine tools and production drilling machines. Self tightening style.

PRECISION INDUSTRIAL LINE



<i>Model No</i>	<i>Drilling capacity mm</i>	<i>Mount</i>	<i>A mm</i>	<i>B mm</i>	<i>C mm</i>	<i>Packaging style</i>	<i>Weight g</i>
S32B12	0-6	DIN B12	36	65	73	Individual box	380
S32J1	0-6	JACOBS 1	36	65	73	Individual box	380
S34B12	0-8	DIN B12	36	65	73	Individual box	380
S34J2	0-8	JACOBS 2	36	65	73	Individual box	380
S36B16	0-10	DIN B16	45	81	93	Individual box	740
S36J2	0-10	JACOBS 2	45	81	93	Individual box	740
S36J33	0-10	JACOBS 33	45	81	93	Individual box	740
S38B16	0-13	DIN B16	51,5	93	105	Individual box	1070
S38J33	0-13	JACOBS 33	51,5	93	105	Individual box	1070
S38J6	0-13	JACOBS 6	51,5	93	105	Individual box	1070
S40B16	3-16	DIN B16	57,5	96	110	Individual box	1420
S40B18	3-16	DIN B18	57,5	96	110	Individual box	1420
S40J6	3-16	JACOBS 6	57,5	96	110	Individual box	1420

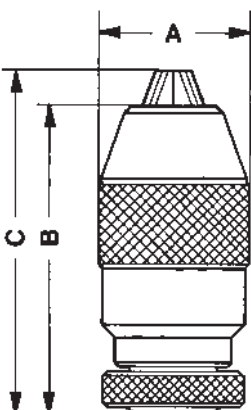

HIGH PRECISION SELF-TIGHTENING KEYLESS CHUCK

With **standard** jaws. Maximum run-out 0.04mm.

All components are heat treated and ground.

Extremely accurate and precise chucks suitable for CNC machines and machine centres.

HIGH PRECISION INDUSTRIAL LINE

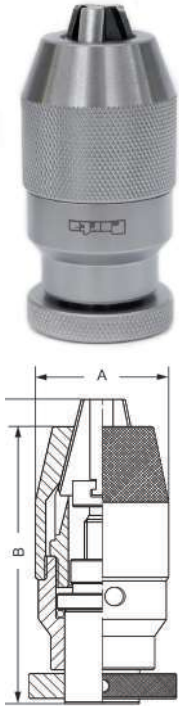

Model No	Drilling capacity mm	Mount	A mm	B mm	C mm	Packaging style	Weight g
PP08B12	0,3-8	B12	37,6	68,4	71,2	Individual box	414
PP08J1	0,3-8	JT1	37,6	68,4	71,2	Individual box	414
PP08J2	0,3-8	JT2	37,6	68,4	71,2	Individual box	414
PP10B12	0,3-10	B12	42,8	80	91,5	Individual box	637
PP10B16	0,3-10	B16	42,8	80	91,5	Individual box	650
PP10J2	0,3-10	JT2	42,8	80	91,5	Individual box	650
PP10J33	0,3-10	JT33	42,8	80	91,5	Individual box	650
PP13J2	0,3-13	JT2	50,4	91,2	104	Individual box	1003
PP13J33	0,3-10	JT33	50,4	91,2	104	Individual box	1003
PP13J6	0,3-10	JT6	50,4	91,2	104	Individual box	994
PP13B16	0,3-10	B16	50,4	91,2	104	Individual box	1003
PP16J6	3-16	JT6	56,7	95,5	108,9	Individual box	1298
PP16J3	0,3-10	JT3	56,7	101,6	104,3	Individual box	1292
PP16J33	0,3-10	JT33	56,7	101,6	104,3	Individual box	1292
PP16B16	0,3-10	B16	56,7	95,6	108,7	Individual box	1305
PP16B18	0,3-10	B18	56,7	103	106,2	Individual box	1319

HIGH PRECISION SELF-TIGHTENING KEYLESS CHUCK

With **titanium** jaws. Maximum run-out 0.04mm.

Extremely accurate and precise chucks suitable for CNC machines and machine centres.

Supplied with spanner wrench to allow the application of supplementary gripping torque.

The high tech titanium increases the grip and wear resistance of the jaw.

HIGH PRECISION INDUSTRIAL LINE



Model No	Drilling capacity mm	Mount	A mm	B mm	C mm	Packaging style	Weight g
PPT06B10	0.3-6.5	B10	33,4	62,4	68,7	Individual box	298
PPT08B12	0.3-8	B12	37,6	68,4	71,2	Individual box	414
PPT08J1	0.3-8	JT1	37,6	68,4	71,2	Individual box	500
PPT08J2	0.3-8	JT2	37,6	68,4	71,2	Individual box	500
PPT10B12	0.3-10	B12	42,8	80	91,5	Individual box	637
PPT10B16	0.3-8	B16	42,8	80	91,5	Individual box	617
PPT10J2	0.3-8	JT2	42,8	80	91,5	Individual box	700
PPT10J33	0.3-8	JT33	42,8	80	91,5	Individual box	700
PPT13J2	0.3-13	JT2	50,4	91,2	104	Individual box	1003
PPT13J33	0.3-13	JT33	50,4	91,2	104	Individual box	1003
PPT13J6	0.3-13	JT6	50,4	91,2	104	Individual box	994
PPT13B16	0.3-13	B16	50,4	91,2	104	Individual box	1003
PPT16J6	3-16	JT6	56,7	95,5	108,9	Individual box	1298
PPT16J3	0.3-13	JT3	56,7	101,6	104,3	Individual box	1292
PPT16J33	0.3-13	JT33	56,7	95,6	108,7	Individual box	1292
PPT16B16	0.3-13	B16	56,7	95,6	108,7	Individual box	1305
PPT16B18	0.3-13	B18	56,7	103	106,2	Individual box	1319

PORTA PRECISION GRADE KEYLESS CHUCKS

For CNC machine tools and machining centres with integral shank.

HIGH PRECISION INDUSTRIAL LINE

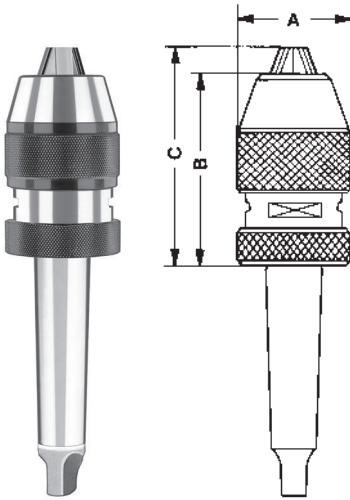

Model No	Drilling capacity mm	Mount	A mm	B mm	C mm	Packaging style	Weight g
MT10MT2	0-10	Morse taper 2	41	81	89	Individual box	990
MT13MT2	1-13	Morse taper 2	50,5	88	99	Individual box	1200
MT13MT3	1-13	Morse taper 3	50,5	88	99	Individual box	1360
MT13MT4	1-13	Morse taper 4	50,5	88	99	Individual box	1628
MT13R8	1-13	R8 Bridgeport	50,5	88	99	Individual box	1435
MT16MT2	3-16	Morse taper 2	56	95	108	Individual box	1580
MT16MT3	3-16	Morse taper 3	56	95	108	Individual box	1690
MT16MT4	3-16	Morse taper 4	56	95	108	Individual box	1980
MT16R8	3-16	R8 Bridgeport	56	95	108	Individual box	1650

PORTA PRECISION GRADE SPARE CHUCKS

For integral shank keyless chucks.

HIGH PRECISION INDUSTRIAL LINE

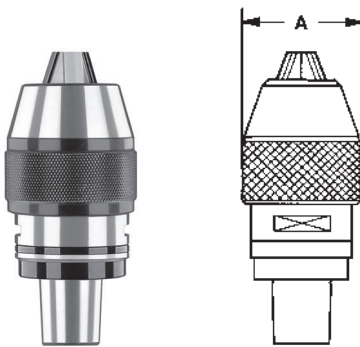

Model No	Drilling capacity mm	Taper size	A mm	Packaging style	Weight g
MP08A	0-8	Morse taper 2	37	Individual box	365
MP10A	0-10	Morse taper 2	41	Individual box	560
MP13A	1-13	Morse taper 3	46	Individual box	785
MP16A	3-16	Morse taper 3	55	Individual box	1100

Way of applications

Model

MP08A

MP10A

MP13A

MP16A

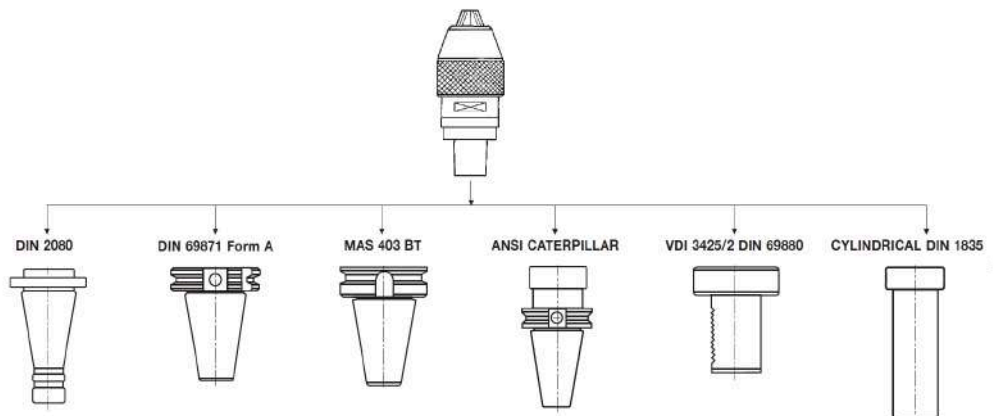

PORTA PRECISION GRADE KEYLESS CHUCKS

With integral shank for CNC machine tools and machining centres. Supplied with milled wrench flats and spanner wrench to allow the application of supplementary gripping torque.

HIGH PRECISION INDUSTRIAL LINE

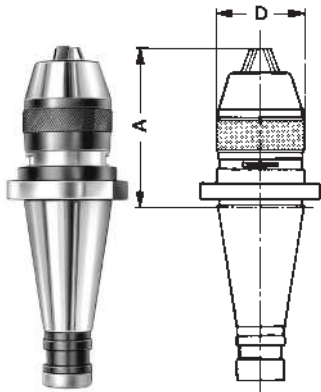

DIN 2080

Model No	Drilling capacity mm	Iso taper size	Drawbolt thread	D mm	A mm min	A mm max	Packaging style	Weight g
MP0840D20	0-8	40	M16	36,5	57	64	Individual box	1005
MP1340D20	1-13	40	M16	48,5	78	90	Individual box	1395
MP1350D20	1-13	50	M24	48,5	75	87	Individual box	3155
MP1640D20	3-16	40	M16	54,5	90	102	Individual box	1730
MP1650D20	3-16	50	M24	54,5	72	84	Individual box	3295

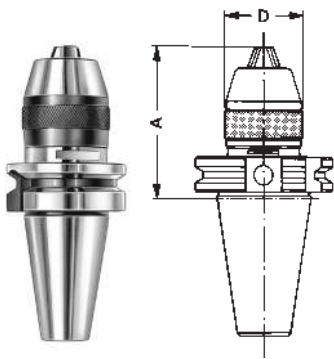

DIN 69871 Form A

Model No	Drilling capacity mm	Iso taper size	Drawbolt thread	D mm	A mm min	A mm max	Packaging style	Weight g
MP0840D69A	0-8	40	M16	36,5	64	71	Individual box	1005
MP1340D69A	1-13	40	M16	48,5	80	92	Individual box	1380
MP1350D69A	1-13	50	M24	48,5	78	90	Individual box	3170
MP1640D69A	3-16	40	M16	54,5	97	106	Individual box	1780
MP1650D69A	3-16	50	M24	54,5	76	88	Individual box	3305

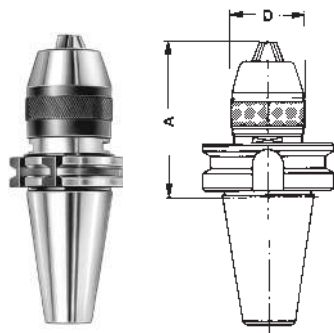

MAS 403 BT

Model No	Drilling capacity mm	Iso taper size	Drawbolt thread	D mm	A mm min	A mm max	Packaging style	Weight g
MP0830MBT	0-8	30	M12	36,5	77	84	Individual box	695
MP0840MBT	0-8	40	M16	36,5	72	79	Individual box	1200
MP1340MBT	1-13	40	M16	48,5	86	98	Individual box	1535
MP1350MBT	1-13	50	M24	48,5	97	109	Individual box	4135
MP1640MBT	3-16	40	M16	54,5	105	117	Individual box	1935
MP1650MBT	3-16	50	M24	54,5	95	107	Individual box	4275

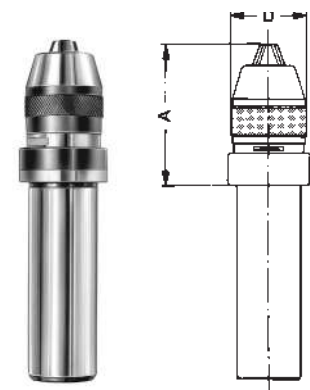

CYLINDRICAL DIN 1835

Model No	Drilling capacity mm	Shank diameter mm	D mm	A mm min	A mm max	Packaging style	Weight g
MP0825CYL	0-8	25	36,5	65	72	Individual box	690
MP1332CYL	1-13	32	48,5	65	72	Individual box	1400
MP1340CYL	1-13	40	48,5	79	91	Individual box	1890
MP1640CYL	3-16	40	54,5	83	95	Individual box	2225

TAURUS RANGE KEYLESS CHUCK

Designed to exceed the performance of conventional drill chucks, the TAURUS range, represents a revolutionary new concept in technology and are precision engineered to enable the operator to lock the bit firmly in the chuck by hand.

- Suitable for Forward, Reverse and Percussion
- Nylon and Full metal version
- Double and single sleeve suitable for conventional and spindle lock machines
- Antilock mechanism
- Standard and Carbide jaw bite
- High performance for machines up to 1100 Watts impact applications

Model numbers ending in letter R indicate chuck supplied with through hole to accommodate a left hand locking screw for reversing tools.

A TORX® wrench can also be used to lock the keyless chucks to the drilling machine spindle.

No left hand screw is needed in this case.

TAURUS LINE

TAURUS REGULAR

Hard nylon two piece sleeve, metal nose cap, suitable for machines in forward and reverse mode.
Hand tightening style.

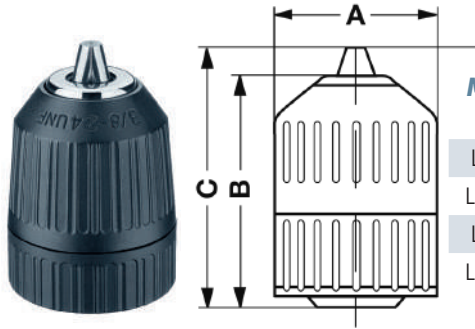

Model No	Drilling capacity mm	Mount	A mm	B mm	C mm	Max machine rating	Packaging style	Weight g
LD10F12R	1.5-10	1/2" x 20	42,7	55	62	Suitable for machines in forward and reverse mode only	Individual box	182
LD10F12RB	1.5-10	1/2" x 20	42,7	55	62		Blister card	182
LD10F38R	1.5-10	3/8" x 24	42,7	55	62		Individual box	182
LD10F38RB	1.5-10	3/8" x 24	42,7	55	62		Blister card	182

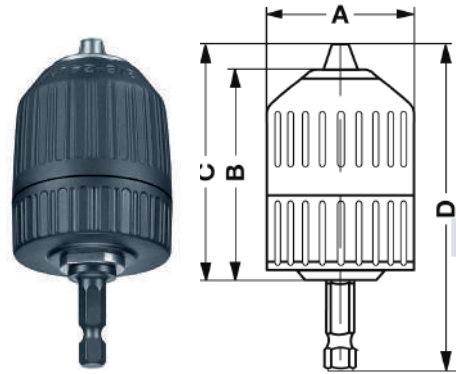

KEYLESS CHUCKS FOR SCREWDRIVERS

with 1/4" male hexagonal mount to DIN 3126 - E 6.3.

Model No	Drilling capacity mm	A mm	B mm	C mm	D mm	Packaging style	Weight g
LD10X1B	1.5-10	42,7	55	62	80	Individual box	200

DIY DESIGN KEYLESS CHUCK - HEX SHANK QUICK CHANGE

Application

- Recommended for Consumer Rotary Drills or Drill Drivers.
- Minimum standard 2.0" (50mm) hex bits are required to use Locking Hex feature.

Features and Benefits

- Locking Hex feature allows for rapid change of hex bits when doing drilling and driving operations without tightening the chuck.
- A snap ball in Hex Mount which provide max 9 lbf retention force.
- Chuck can still be used as normal with round shank bits.
- For larger diameter drill bits, where tightening the chuck would be recommended.
- Locking Hex feature would properly align jaws to hex flats on the drill shank.

TAURUS LINE



Model No	Chuck capacity mm	Mount	Screwdriver bit hole (mm)	Dimensions (mm)			Weight g
				Diameter	Length close	Length open	
LD10F38RHEX	1-10	3/8-24	H1/4" 6.35mm	45,5	55,5	65	180
LD13F12RHEX	1,5-10	1/2-20	H1/4" 6.35mm	42,6	55	70	238

TAURUS RANGE KEYLESS CHUCK

TAURUS PROFESSIONAL LINE

TAURUS PROFESSIONAL

Hard nylon two piece sleeve, metal nose cap, suitable for machines in forward, reverse and percussion mode. Hand tightening style.

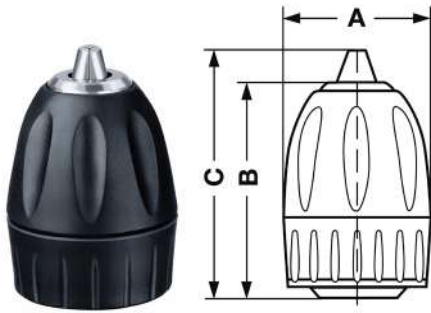

Model No	Drilling capacity mm	Mount	A mm	B mm	C mm	Max machine rating	Packaging style	Weight g
LDP10F12R	1,5-10	1/2" x 20	42,7	55	63	450 W	Individual box	172
LDP10F12RB	1,5-10	1/2" x 20	42,7	55	63	450 W	Blister card	172
LDP10F38R	1,5-10	3/8" x 24	42,7	55	63	450 W	Individual box	172
LDP10F38RB	1,5-10	3/8" x 24	42,7	55	63	450 W	Blister card	172

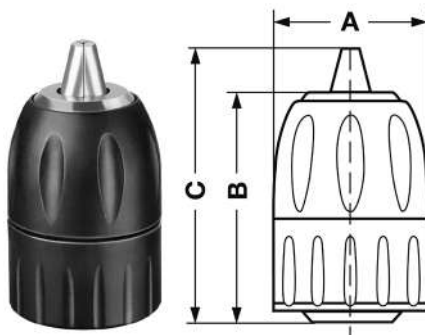

Model No	Drilling capacity mm	Mount	A mm	B mm	C mm	Max machine rating	Packaging style	Weight g
LDP13F12R	2-13	1/2" x 20	42,7	62	76	710 W	Individual box	290
LDP13F12RB	2-13	1/2" x 20	42,7	62	76	710 W	Blister card	290
LDP13F38R	2-13	3/8" x 24	42,7	62	76	710 W	Individual box	290
LDP13F38RB	2-13	3/8" x 24	42,7	62	76	710 W	Blister card	290
LDP13SDS	2-13	SDS	42,7	62	76	710 W	Individual box	330
LDP13SDSB	2-13	SDS	42,7	62	76	710 W	Blister card	330

TAURUS PROFESSIONAL - SPINDLE LOCK SYSTEM

For machines with Spindle Lock system. Hard nylon single sleeve suitable for forward, reverse and percussion mode.

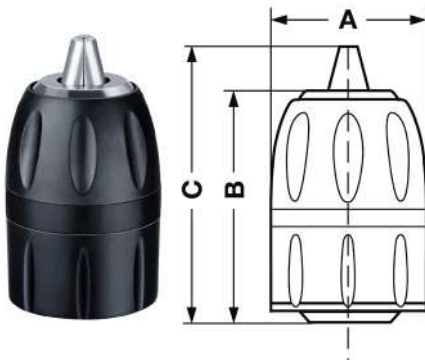

Model No	Drilling capacity mm	Mount	A mm	B mm	C mm	Max machine rating	Packaging style	Weight g
LDPS13F12R	2-13	1/2" x 20	42,7	62	73	710 W	Individual box	280
LDPS13F12RB	2-13	1/2" x 20	42,7	62	73	710 W	Blister card	280

TAURUS PROFESSIONAL

For impact drivers

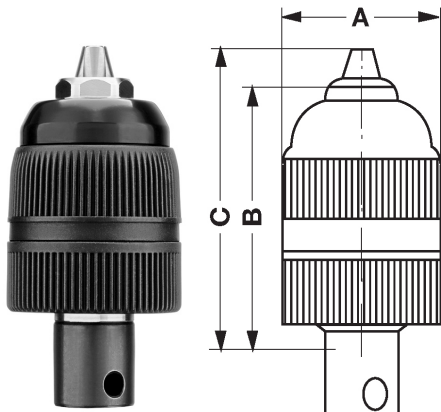

Model No	Drilling capacity mm	Mount	A mm	B mm	C mm	Max machine rating	Packaging style	Weight g
LDP10SQ38	1-10	Quadro 3/8"	41	77	85	100 Nm	Individual box	232
LDP10SQ12	1-10	Quadro 1/2"	41	80	88	100 Nm	Individual box	263

TAURUS SUPER CHUCKS

Suitable for forward, reverse and impact mode.
Standard jaws with serrated bite.

TAURUS SUPER LINE

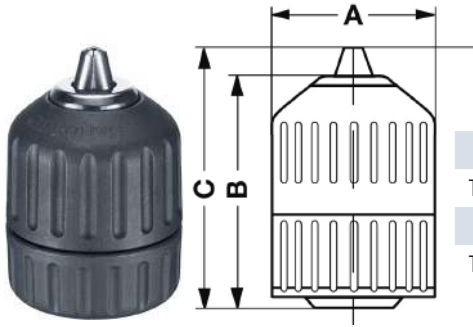

HARD NYLON TWO PIECE SLEEVE

Model No	Drilling capacity mm	Mount	A mm	B mm	C mm	Max machine rating	Packaging style	Weight g
TSP10F12R	1,5-10	1/2" x 20	42,7	55	64	1100 W	Individual box	165
TSP10F12RB	1,5-10	1/2" x 20	42,7	55	64	1100 W	Blister card	165
TSP10F38R	1,5-10	3/8" x 24	42,7	55	64	1100 W	Individual box	165
TSP10F38RB	1,5-10	3/8" x 24	42,7	55	64	1100 W	Blister card	165

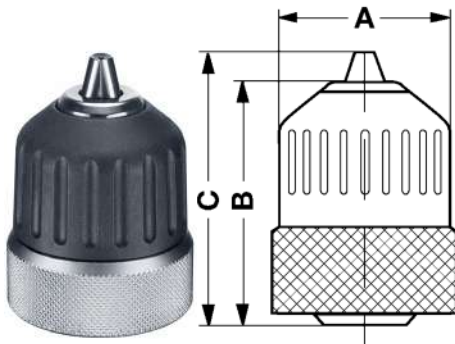

HARD NYLON FRONT SLEEVE AND REAR METAL SLEEVE

Model No	Drilling capacity mm	Mount	A mm	B mm	C mm	Max machine rating	Packaging style	Weight g
TSMP10F12R	1,5-10	1/2" x 20	42,7	55	64	1100 W	Individual box	195
TSMP10F12RB	1,5-10	1/2" x 20	42,7	55	64	1100 W	Blister card	195
TSMP10F38R	1,5-10	3/8" x 24	42,7	55	64	1100 W	Individual box	195
TSMP10F38RB	1,5-10	3/8" x 24	42,7	55	64	1100 W	Blister card	195

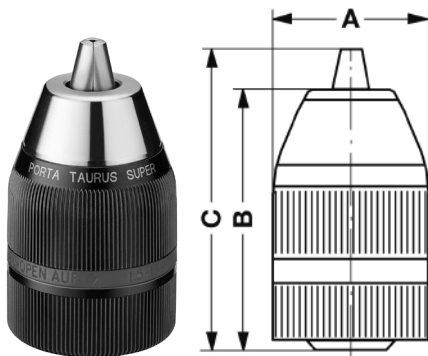

HARD NYLON TWO PIECE SLEEVE

Model No	Drilling capacity mm	Mount	A mm	B mm	C mm	Max machine rating	Packaging style	Weight g
TSP13F12R	1,5-13	1/2" x 20	42,7	64	75,3	1100 W	Individual box	260
TSP13F12RB	1,5-13	1/2" x 20	42,7	64	75,3	1100 W	Blister card	260

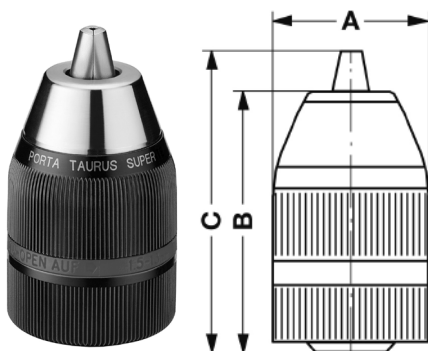

FULL METAL TWO PIECE SLEEVE

Model No	Drilling capacity mm	Mount	A mm	B mm	C mm	Max machine rating	Packaging style	Weight g
TS13F12R	1,5-13	1/2" x 20	42,7	64	75,3	1100 W	Individual box	295
TS13F12RB	1,5-13	1/2" x 20	42,7	64	75,3	1100 W	Blister card	295
TS13F38R	1,5-13	3/8" x 24	42,7	64	75,3	1100 W	Individual box	295
TS13F38RB	1,5-13	3/8" x 24	42,7	64	75,3	1100 W	Blister card	295
TS13SDS	1,5-13	3/8" x 24	42,7	64	75,3	1100 W	Individual box	340
TS13SDSB	1,5-13	SDS	42,7	64	75,3	1100 W	Blister card	340

TAURUS SUPER - SPINDLE LOCK SYSTEM

For machines with Spindle Lock system, suitable for forward, reverse and impact mode. Standard jaws with serrated bite.

TAURUS SUPER LINE

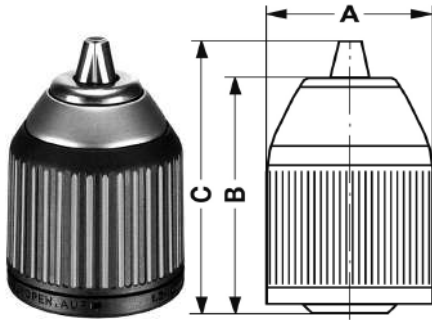

HARD NYLON SINGLE SLEEVE

<i>Model No</i>	<i>Drilling capacity mm</i>	<i>Mount</i>	<i>A mm</i>	<i>B mm</i>	<i>C mm</i>	<i>Max machine rating</i>	<i>Packaging style</i>	<i>Weight g</i>
TSSP10F12R	1,5-10	1/2" x 20	42,7	57,5	64	1100 W	Individual box	161
TSSP10F12RB	1,5-10	1/2" x 20	42,7	57,5	64	1100 W	Blister card	161
TSSP10F38R	1,5-10	3/8" x 24	42,7	57,5	64	1100 W	Individual box	161
TSSP10F38RB	1,5-10	3/8" x 24	42,7	57,5	64	1100 W	Blister card	161

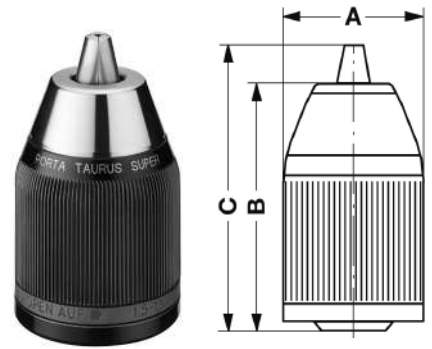

FULL METAL SINGLE SLEEVE

<i>Model No</i>	<i>Drilling capacity mm</i>	<i>Mount</i>	<i>A mm</i>	<i>B mm</i>	<i>C mm</i>	<i>Max machine rating</i>	<i>Packaging style</i>	<i>Weight g</i>
TSS13F12R	1,5-13	1/2" x 20	42,9	53,5	69	1100 W	Individual box	295
TSS13F12RB	1,5-13	1/2" x 20	42,9	53,5	69	1100 W	Blister card	295
TSS13F916R	1,5-13	9/16"x18	42,9	53,5	69	1100 W	Individual box	248
TSS13F916RB	1,5-13	9/16"x18	42,9	53,5	69	1100 W	Blister card	248

TAURUS ULTIMATE CHUCKS

Suitable for forward, reverse and impact mode. Carbide jaw bite to ensure better gripping.

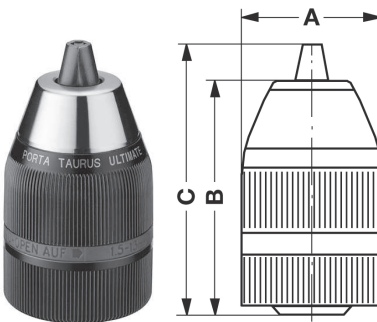
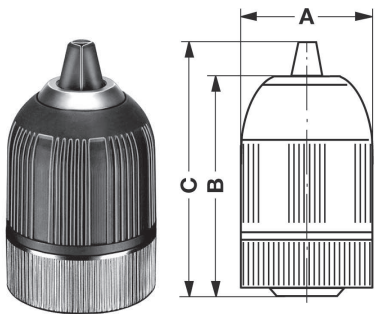
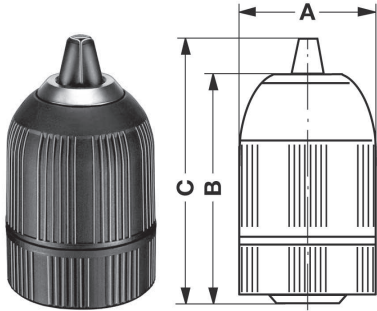

TAURUS ULTIMATE LINE



HARD NYLON TWO PIECE SLEEVE

Model No	Drilling capacity mm	Mount	A mm	B mm	C mm	Max machine rating	Packaging style	Weight g
TUP13F12R	1,5-13	1/2" x 20	42,7	63,5	75,3	1100 W	Individual box	248
TUP13F12RB	1,5-13	1/2" x 20	42,7	63,5	75,3	1100 W	Blister card	248

HARD NYLON FRONT SLEEVE AND REAR METAL SLEEVE

Model No	Drilling capacity mm	Mount	A mm	B mm	C mm	Max machine rating	Packaging style	Weight gr.
TUMP13F12R	1.5-13	1/2" x 20	42,7	63,5	75,3	1100 W	Individual box	282
TUMP13F12RB	1.5-13	1/2" x 20	42,7	63,5	75,3	1100 W	Blister card	282

FULL METAL TWO PIECE SLEEVE

Model No	Drilling capacity mm	Mount	A mm	B mm	C mm	Max machine rating	Packaging style	Weight gr.
TU13F12R	1.5-13	1/2" x 20	42,7	63,5	75,3	1100 W	Individual box	282
TU13F12RB	1.5-13	1/2" x 20	42,7	63,5	75,3	1100 W	Blister card	282

ULTIMATE SPINDLE-LOCK CHUCKS

For machines with Spindle Lock system, suitable for forward, reverse and impact mode. Carbide jaws.

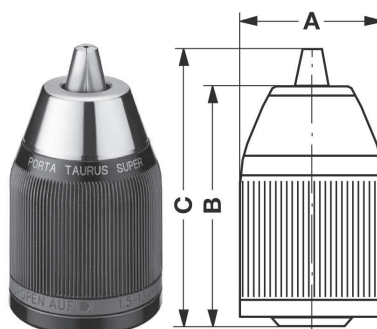

TAURUS ULTIMATE LINE

Model No	Drilling capacity mm	Mount	A mm	B mm	C mm	Max machine rating	Packaging style	Weight gr.
TUS13F12R	1.5-13	1/2" x 20	42,7	64	75,3	1100 W	Individual box	295
TUS13F12RB	1.5-13	1/2" x 20	42,7	64	75,3	1100 W	Blister card	295

IMPACT CHUCK

With locking collar for percussion drills, carbide jaws.
Only clockwise rotation - not reversible

INDUSTRIAL LINE

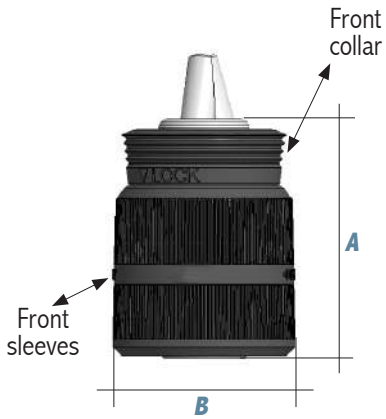

FEATURE

Capacity mm	Material of sleeve	Jaws	A mm	B mm	Pull force of front collar	Weight g
1,6-13	Plastic	Carbide	56	42,7	20N+/-10N	260

HOW TO USE THE CHUCK

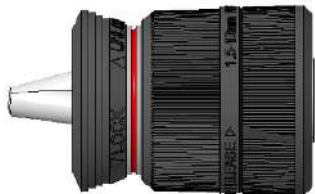

STEP 1:

Pull out the front collar by hand. A red line will appear.

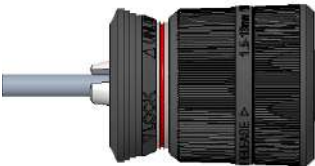

STEP 2:

Like a traditional chuck, rotate front sleeve to open and close the chuck

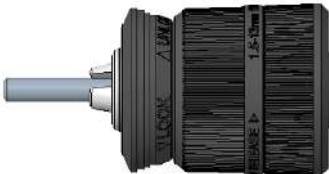

STEP 3:

After chuck is tightened on the bit, press the front collar by hand to lock the sleeve. The red line disappears.

AVAILABLE MODELS



Model No	Mount	Max torque	Application
TUPID13F12R	1/2 Female thr.	113N.m	Drill



Model No	Mount	Max torque	Application
TUPID13X1	1/4 hex	67N.m	Impact driver



Model No	Mount	Max torque	Application
TUPID13SQ12	1/2 square	113N.m	Impact wrench

KEY OPERATED CHUCKS

Medium duty for professional users of power tools, bench drilling machines, and woodworking machinery.
Heavy duty for production drilling machines and industrial power tools.
Packed in individual cartons with key.

INDUSTRIAL LINE

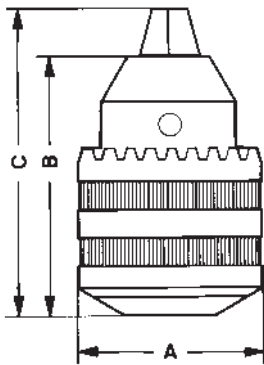

Model No	Drilling capacity mm	Mount	Through hole diameter mm	With key	A mm	B mm	C mm	Packaging style	Weight g
A04J0	0.5-4	JACOBS 0	—	K0	22	29	35	Individual box	80
A06B10	0.3-6	DIN B10	—	KS1	32	40	50	Individual box	135
A06F38	0.5-6	Mount femmina 3/8" x 24	—	KS1	32	40	50	Individual box	135
A06F38R	0.5-6	Mount femmina 3/8" x 24	5,5	KS1	32	40	50	Individual box	135
A08B12	0.3-8	DIN B12	—	KS1	30	44	54	Individual box	140
A08J1	0.3-8	JACOBS 1	—	KS1	30	44	54	Individual box	140
A08F38	0.3-8	Mount femmina 3/8" x 24	—	KS1	30	44	54	Individual box	140
A08F38R	0.3-8	Mount femmina 3/8" x 24	5,5	KS1	30	44	54	Individual box	140
A10B12	0.5-10	DIN B12	—	KS2	36,5	51	60	Individual box	220
A10J2	0.5-10	JACOBS 2	—	KS2	36,5	51	60	Individual box	220
A10F38	0.5-10	Mount femmina 3/8" x 24	—	KS2	36,5	51	60	Individual box	220
A10F38R	0.5-10	Mount femmina 3/8" x 24	5,5	KS2	36,5	51	60	Individual box	220
A10F12	0.5-10	Mount femmina 1/2" x 20	—	KS2	36,5	51	60	Individual box	220
A10F12R	0.5-10	Mount femmina 1/2" x 20	6,5	KS2	36,5	51	60	Individual box	220
A13B12	1.5-13	DIN B12	—	KS2	42,5	59	73	Individual box	370
A13B16	1.5-13	DIN B16	—	KS2	42,5	59	73	Individual box	370
A13J6	1.5-13	JACOBS 6	—	KS2	42,5	59	73	Individual box	370
A13J33	1.5-13	JACOBS 33	—	KS2	42,5	59	73	Individual box	370
A13F38	1.5-13	Mount femmina 3/8" x 24	—	KS2	42,5	59	73	Individual box	370
A13F38R	1.5-13	Mount femmina 3/8" x 24	5,5	KS2	42,5	59	73	Individual box	370
A13F12	1.5-13	Mount femmina 1/2" x 20	—	KS2	42,5	59	73	Individual box	370
A13F12R	1.5-13	Mount femmina 1/2" x 20	6,5	KS2	42,5	59	73	Individual box	370
AP13B16	0.5-13	DIN B16	—	KS3	53	66	89	Individual box	615
AP13J6	0.5-13	JACOBS 6	—	KS3	53	66	89	Individual box	615
AP13J2	0.5-13	JACOBS 2	—	KS3	51	72	92	Individual box	635
AP13J33	0.5-13	JACOBS 33	—	KS3	53	66	89	Individual box	615
AP13F58	0.5-13	Mount femmina 5/8" x 16	—	KS3	53	66	89	Individual box	635
AP16B16	2.5-16	DIN B16	—	KS3	54	67	86	Individual box	627
AP16B18	2.5-16	DIN B18	—	KS3	54	67	86	Individual box	627
AP16J6	2.5-16	JACOBS 6	—	KS3	54	67	86	Individual box	627
AP16J33	2.5-16	JACOBS 33	—	KS3	54	67	86	Individual box	627
AP16F12	2.5-16	Mount femmina 1/2" x 20	—	KS3	54	67	86	Individual box	627
AP16F12R	2.5-16	Mount femmina 1/2" x 20	6,5	KS3	54	67	86	Individual box	627
AP16F58	2.5-16	Mount femmina 5/8" x 16	—	KS3	54	67	86	Individual box	627
AP16F58R	2.5-16	Mount femmina 5/8" x 16	6,5	KS3	54	67	86	Individual box	627
APP16B18	0.5-16	DIN B18	—	KS3	57	79	102	Individual box	880
APP16J6	0.5-16	JACOBS 6	—	KS3	57	79	102	Individual box	880
APP16J3	0.5-16	JACOBS 3	—	KS3	57	79	102	Individual box	880
APP16F58	0.5-16	Mount femmina 5/8" x 16	—	KS3	57	79	102	Individual box	880
AP20B22	5-20	DIN B22	—	KS4	64	92	116	Individual box	1095
AP20J3	5-20	JACOBS 3	—	KS4	64	92	116	Individual box	1095
*AP20F34	5-20	Mount femmina 3/4" x 16	—	KS3	62	80	99	Individual box	913
AP26B24	5-26	DIN B24	—	KS4	75	144	139	Individual box	2095
AP26J4	5-26	JACOBS 4	—	KS4	75	144	139	Individual box	2095

* Clearance sale

STANDARD DUTY KEY OPERATED CHUCKS

Model numbers ending in letter R indicate chuck supplied with through hole to accommodate a left hand locking screw for reversing tools.

STANDARD LINE

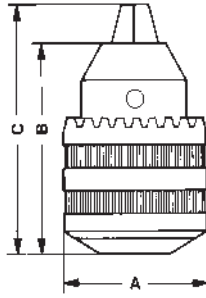

Model No	Drilling capacity mm	Mount	Through hole diameter mm	With key	A	B	C	Packaging style	Weight g
AH06F38R	0-6	Female thr. 3/8" x 24	5,5	KH810	30	40	50,5	Individual box	112
AH06F38RB	0-6	Female thr. 3/8" x 24	5,5	KH810	30	40	50,5	Blister card card	112
AH10B12	1,5-10	DIN B12	—	KH810	33	49	60	Individual box	160
AH10M38	1,5-10	Male thr. 3/8" x 24	—	KH810	33	49	60	Individual box	180
AH10M38B	1,5-10	Male thr. 3/8" x 24	—	KH810	33	49	60	Blister card card	180
AH10F38	1,5-10	Female thr. 3/8" x 24	—	KH810	33	49	60	Individual box	165
AH10F38R	1,5-10	Female thr. 3/8" x 24	5,5	KH810	33	49	60	Individual box	165
AH10F38B	1,5-10	Female thr. 3/8" x 24	—	KH810	33	49	60	Blister card card	165
AH10F38RB	1,5-10	Female thr. 3/8" x 24	5,5	KH810	33	49	60	Blister card card	160
AH10F12	1,5-10	Female thr. 1/2" x 20	—	KH810	33	49	60	Individual box	160
AH10F12R	1,5-10	Female thr. 1/2" x 20	6,5	KH810	33	49	60	Individual box	160
AH10F12B	1,5-10	Female thr. 1/2" x 20	—	KH810	33	49	60	Blister card card	160
AH10F12RB	1,5-10	Female thr. 1/2" x 20	6,5	KH810	33	49	60	Blister card card	160
AH13B12	1,5-13	DIN B12	—	KS2	42,5	59	74	Individual box	280
AH13B16	1,5-13	DIN B16	—	KS2	42,5	59	74	Individual box	280
AH13M38	1,5-13	Male thr. 3/8" x 24	—	KS2	42,5	59	74	Individual box	295
AH13M38B	1,5-13	Male thr. 3/8" x 24	—	KS2	42,5	59	74	Blister card card	295
AH13F38	1,5-13	Female thr. 3/8" x 24	—	KS2	42,5	59	74	Individual box	285
AH13F38R	1,5-13	Female thr. 3/8" x 24	5,5	KS2	42,5	59	74	Individual box	285
AH13F38B	1,5-13	Female thr. 3/8" x 24	—	KS2	42,5	59	74	Blister card card	285
AH13F38RB	1,5-13	Female thr. 3/8" x 24	5,5	KS2	42,5	59	74	Blister card card	280
AH13F12	1,5-13	Female thr. 1/2" x 20	—	KS2	42,5	59	74	Individual box	280
AH13F12R	1,5-13	Female thr. 1/2" x 20	6,5	KS2	42,5	59	74	Individual box	280
AH13F12B	1,5-13	Female thr. 1/2" x 20	—	KS2	42,5	59	74	Blister card card	280
AH13F12RB	1,5-13	Female thr. 1/2" x 20	6,5	KS2	42,5	59	74	Blister card card	280
AH13SDS	1,5-13	SDS	6,5	KS2	42,5	59	74	Individual box	330
AH13SDSB	1,5-13	SDS	6,5	KS2	42,5	59	74	Blister card card	330
AH16F12R	3-16	Female thr. 1/2" x 20	—	KS3	49,4	69	87,5	Individual box	604

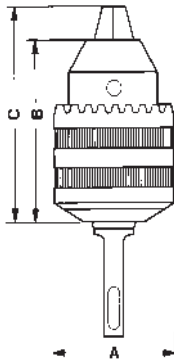

KEY OPERATED CHUCKS FOR SCREWDRIVERS

With 1/4" hexagonal male mount to DIN 3126 - E 6.3

STANDARD LINE

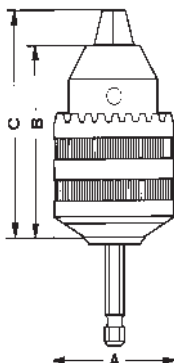

Model No	Drilling capacity mm	With key	A mm	B mm	C mm	Packaging style	Weight g
AH06X1	0-6	KH810	30	40	50,5	Individual box	126
AH06X1B	0-6	KH810	30	40	50,5	Blister card card	126
AH10X1	1,5-10	KH810	33	49	60	Individual box	180
AH10X1B	1,5-10	KH810	33	49	60	Blister card card	180

KEY OPERATED CHUCKS

Standard duty key operated chucks nickel plated.

NICKEL PLATED LINE

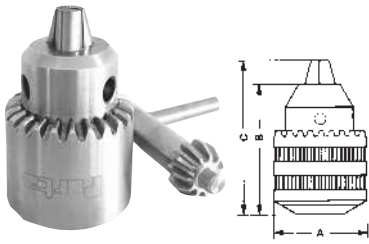

Model No	Drilling capacity mm	Mount	Through hole diameter mm	With key	A mm	B mm	C mm	Packaging style	Weight g
AH10F38RNP	1,5-10	Female thr. 3/8" x 24	5,5	KH810	33	40	58,6	Individual box	120

KEY OPERATED CHUCKS

Stainless steel key operated chucks for use specifically in medical, chemical and food sector.

STAINLESS STEEL LINE

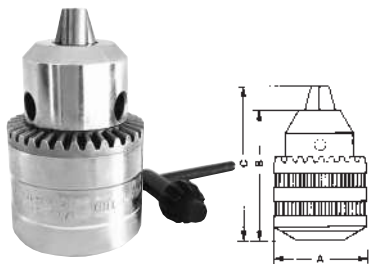

Model No	Drilling capacity mm	Mount	With key	A mm	B mm	C mm	Packaging style	Weight g
SSA06F38	0.3-6.5mm	3/8-24UNF	SS-S1	28,5	40,5	49	Individual box	170
SSA10F38	0.3-10mm	3/8-24UNF	SS-S2	39	51	63	Individual box	295

BALL BEARING DRILL CHUCK WITH KEY

For production drilling equipment.

Drill chuck with key for industrial applications that require the toughest machining conditions.

- Equipped with ball bearings to reduce frictions in the tightening mechanism and provide a better grip on the drill shaft.
- All the pieces are hardened and ground.
- Range up to 20 mm capacity.
- Run-out: 0,08mm max.

PRECISION LINE

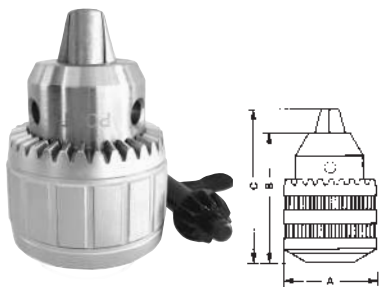

Model No	Jacobs equivalent	Capacity mm	Mount	Key type	A mm	B mm	C mm	Packaging style	Weight g
APBB10J2	11N	1-10	JT2	KS8	43	56	72	Individual box	215
APBB13J3	14N	1-13	JT3	KS3	53	73	96	Individual box	615
APBB16J3	16N	3-16	JT3	KS3	53	74	97	Individual box	645
APBB20J4	18N	5-20	JT4	KS4	64	96	121	Individual box	1095

HAMMER KEY TYPE DRILL CHUCKS

With SDS Adaptor.

Application: for hammer drilling in concrete, stone, etc.

Technical feature: clockwise and counterclockwise rotation; chuck end play for transmitting the entire impact onto the drill; SDS adaptor; reliable axial locking structure; rubber cap for dust protection; suitable for up to 1050 Watt impact drill or up to 750 Watt hammer drill.

HAMMER LINE



Model No	Capacity mm	Mount	Ø max mm	Lenth mm	Key size	Weight g
A13PKSDS	15-13	SDS	42,9	81,5	KS2PK with long welded handle	420

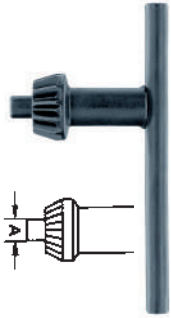

Model No	Key model	Standard	A mm	Teeth No	For key chucks type	Packaging style	Weight g
KS1	KS1	DIN S1	4	10	A06-A08	Bulk	10
KS1B	KS1	DIN S1	4	10	A06-A08	Blister card	10
KS1P50	KS1	DIN S1	4	10	A06-A08	50 pcs. box	10
KS2	KS2	DIN S2	6	12	A10-A13-AH16-AH13	Bulk	40
KS2B	KS2	DIN S2	6	12	A10-A13-AH16-AH13	Blister card	40
KS2P50	KS2	DIN S2	6	12	A10-A13-AH16-AH13	50 pcs. box	40
KS2PK	KS2PK	DIN S2	6	12	—	Bulk	59
KS3	KS3	DIN S3	8	12	AP13-AP16 APP16	Bulk	80
KS3B	KS3	DIN S3	8	12	AP13-AP16 APP16	Blister card	80
KS3P25	KS3	DIN S3	8	12	AP13-AP16 APP16	25 pcs. box	80
KH810	KH810	DIN S14 -JACOBS KG	6	11	AH10	Bulk	20
KH810B	KH810	DIN S14 -JACOBS KG	6	11	AH10	Blister card	20
KH810P50	KH810	DIN S14 -JACOBS KG	6	11	AH10	50 pcs. box	20
K20	K20	DIN S13 - JACOBS K4	9,5	12	-	Bulk	120
KS8	KS8	DIN S8 - JACOBS K30S	6	10	Black & Decker 13mm	Bulk	40
KS8B	KS8	DIN S8 - JACOBS K30S	6	10	Black & Decker 13mm	Blister card	40
KS8P50	KS8	DIN S8 - JACOBS K30S	6	10	Black & Decker 13mm	50 pcs. box	40
K1	K1	DIN S7 - JACOBS K1	4	11	—	Bulk	10
K1B	K1	DIN S7 - JACOBS K1	4	11	—	Blister card	10
K2	K2	JACOBS K2	6,3	11	—	Bulk	40
K2B	K2	JACOBS K2	6,3	11	—	Blister card	40
K32	K32	DIN S9 - JACOBS K32	6,3	10	—	Bulk	60
K32B	K32	DIN S9 - JACOBS K32	6,3	10	—	Blister card	60
KS10	KS10	DIN S10 - JACOBS K3	8	11	—	Bulk	70
KS10B	KS10	DIN S10 - JACOBS K3	8	11	—	Blister card	70
KS4	KS4	DIN S4	9	14	AP20-AP26	Bulk	150
KS4B	KS4	DIN S4	9	14	AP20-AP26	Blister card	150
K0	K0	JACOBS K0	3	11	A04	Bulk	20
K0B	K0	JACOBS K0	3	11	A04	Blister card	20
KJ6	KJ6	CK-3	4	12	Makita 6 mm	Bulk	36
KJ6B	KJ6	CK-3	4	12	Makita 6 mm	Blister card	36
KJ10	KJ10	CK-4	5,5	12	Makita 10 mm	Bulk	53
KJ10B	KJ10	CK-4	5,5	12	Makita 10 mm	Blister card	53
KJ13	KJ13	CK-5	6,5	12	Makita 13 mm	Bulk	61
KJ13B	KJ13	CK-5	6,5	12	Makita 13 mm	Blister card	61
KL0		Rubber strap to attach key on power tool cable				Bulk	—

MORSE TAPER EJECTING DRIFTS

According to DIN 317, hardened and black oxide special steel.



ACCESSORIES

Model No	Morse taper	Lenght mm	Packaging style	Weight g
DR0	0	90	Bulk	14
DR12	1-2	140	Bulk	70
DR23	2-3	148	Bulk	80
DR3	3-4	190	Bulk	150
DR4	4-5	225	Bulk	310
DR56	5-6	265	Bulk	650

SEMI-AUTOMATIC EXTRACTORS

For tools with Morse taper DIN 228.



Model No	Morse taper	Lenght mm	Packaging style	Weight g
DRA123	1-2-3	322	Bulk	320
DRA456	4-5-6	348	Bulk	580

EXTRACTOR FOR ACCESSORY SPINDLES



Model No	Suitable for taper	Dimentions (mm) Lenght Thickness	Weight g
DRCH	B16/I2/I33 da un lato B18/I6 dall'altro lato	210 12	567

NAIL ATTACHMENT

With SDS adaptor to be fitted in a percussion power tool. A magnetic disc on front side provide nail catching for a quick and easy riveting.

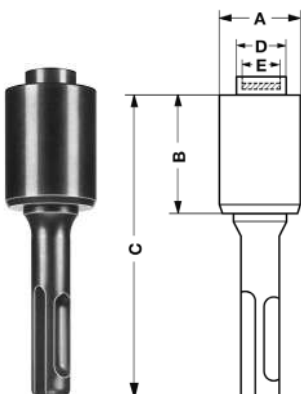

Model No	A mm	B mm	C mm	D mm	E Max size of nail head mm	Packaging style	Weight g
NASDS	23	29	78	13	10	Individual box	100
NASDSB	23	29	78	13	10	Blister card	100

RIGHT ANGLE DRILL ATTACHMENT

The Right Angle Drill Attachment enables drilling of holes where no other conventional drill will fit.

Fits to any drill with 10 mm or larger capacity chuck.

The Right Angle Drill Attachment is equipped with a 3/8" x 24 threaded mount and can be supplied:

- Without chuck code RADA
- With key type chuck code RADACK
- With keyless chuck code RADACL
- Double heat treated helical gear.
- Aluminum alloy metal housing industrial quality guaranteed.
- Gear ratio 1:1,3
- Max drilling capacity: 10 mm in steel, 16 mm in wood.
- Maximum speed: 2.100 rpm. - Max torque: 29,4 Nm.

ACCESSORIES

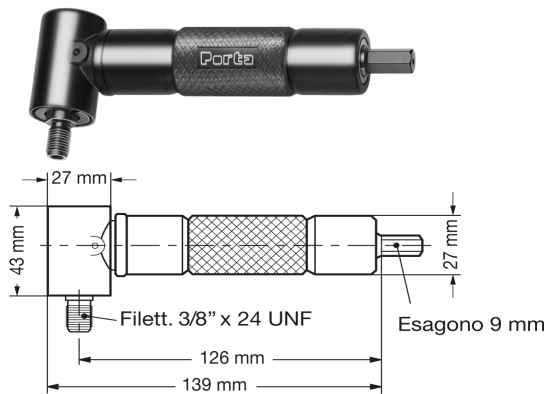

Model No

Packaging style

Weight g

RADA	Individual box	310
RADAB	Blister card	310

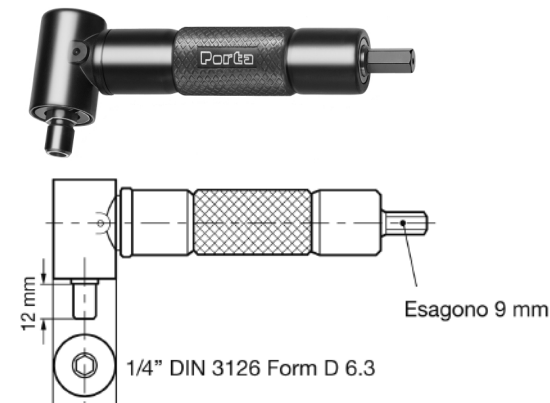

This model for screw driving applications only. It's equipped with magnetic hexagon hole to insert screwing bits.

Model No

Packaging style

Weight g

RADAX	Individual box	315
RADAXB	Blister card	315

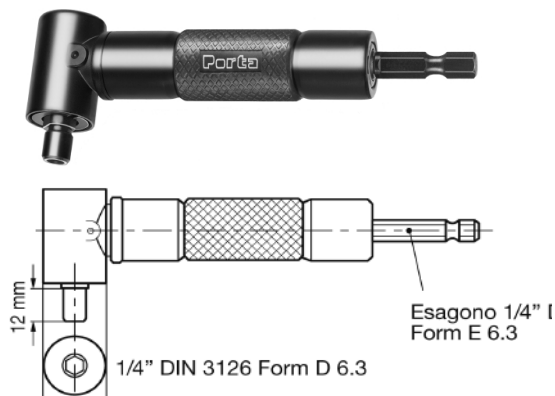

Model No

Packaging style

Weight g

RADAV	Individual box	315
RADAVB	Blister card	315

RIGHT ANGLE DRILL ATTACHMENT - cont.

ACCESSORIES

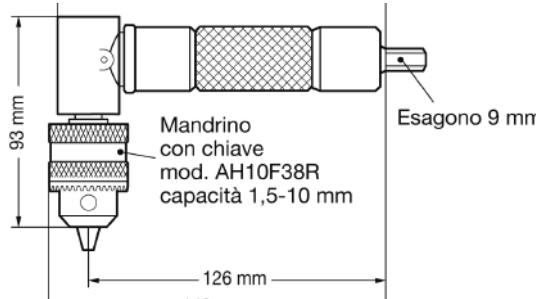

Model No

Packaging style

Weight g

RADACK

Individual box

455

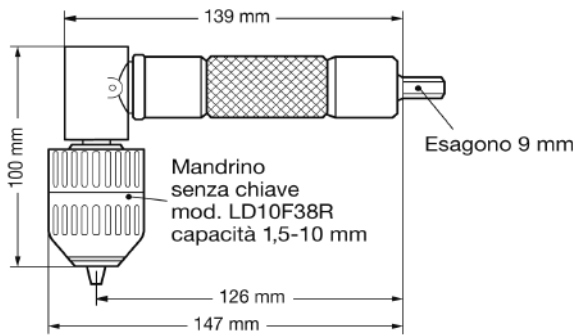

Model No

Packaging style

Weight g

RADACL

Individual box

490

SPARE PARTS

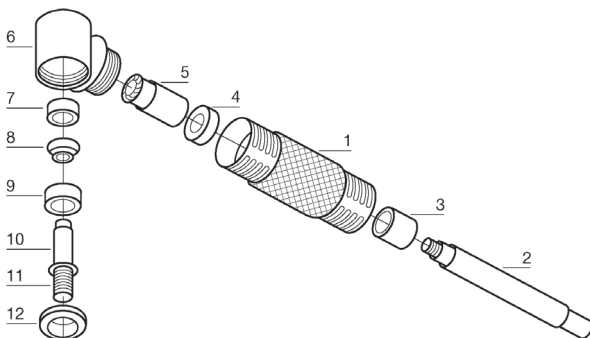

Model No

Item n.

Description

Quantity

XRADA01	1	Body with bushing	1
XRADA02	2	Clutch pin	1
XRADA03	3	Needle bearing	1
XRADA04	4	Ball bearing	1
XRADA05	5	Bevel gear pin	1
XRADA06	6	Angle head	1
XRADA07	7	Ball bearing	1
XRADA08	8	Bevel gear	1
XRADA09	9	Ball bearing	1
XRADA10	10	Key	1
XRADA11	11	Chuck casing	1
XRADA12	12	Bearing cap	1

PROFESSIONAL RIGHT ANGLE DRILL ATTACHMENT

Heavy duty Professional RADA with quick release bit holder (9H) and handle.

MAX Torque 100 N.m.

Gear Ratio: 1:1.28

Code: RADAQXPRO

ACCESSORIES

**Model No****Packaging style****Weight g**

RADAQXPRO

Individual box

689

PROFESSIONAL RIGHT ANGLE DRILL ATTACHMENT

Heavy duty Professional RADA with 3/8" x 24 threaded head to fasten a chuck and handle.

MAX Torque 100 N.m.

Gear Ratio: 1:1.28

Code: RADAPRO

ACCESSORIES

**Model No****Packaging style****Weight g**

RADAPRO

Individual box

689

360° RIGHT ANGLE DRILL ATTACHMENT

This right angle drill attachment with a 360° full rotation enables drilling of holes and screwdriving where no other conventional drill will fit. It can be fitted on all standard power tools and screw drivers. A T Key wrench available in the package can lock the tool at the desired angle.

ACCESSORIES

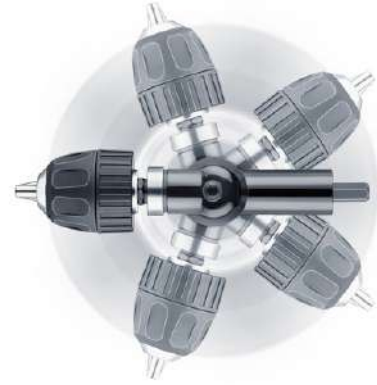
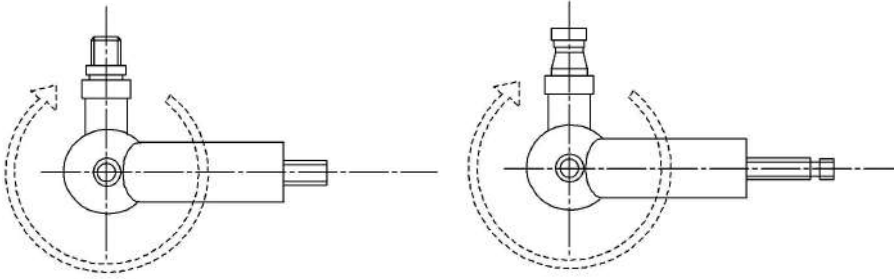

ON DRILLING POWER TOOLS

Connection to the drill chuck via a 9 mm hexagon
 • Max speed: 3500 rpm. • Max torque: 35 Nm

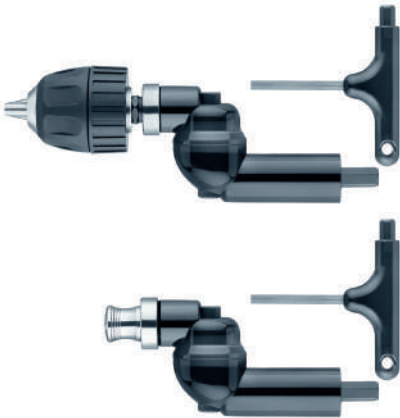

Model No	Supplied with	Capacity mm	Packaging style	Weight g
RADA360CL	Keyless chuck LD10F38R	1,5-10	Individual box	465

Model No	Supplied with	Packaging style	Weight g
RADAQ360	Quick charge chuck for bit	Individual box	301

ON SCREWDRIVERS

Connection to the electric tool via 1/4" hexagon DIN 3126 Form D6.3
 • Max speed: 3500 rpm. • Max torque: 35 Nm

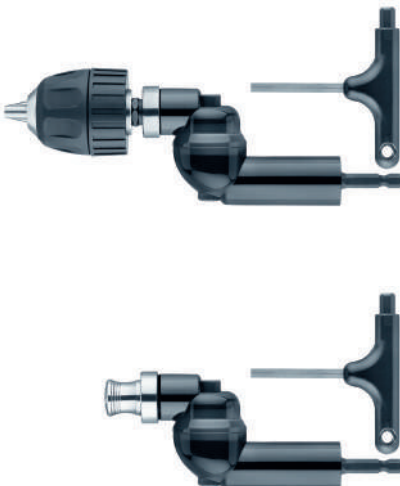

Model No	Supplied with	Capacity mm	Packaging style	Weight g
RADAV360CL	Keyless chuck LD10F38R	1,5-10	Individual box	465

Model No	Supplied with	Packaging style	Weight g
RADAQ360	Quick charge chuck for bit	Individual box	301

QUICK CHANGE SDS CONVERTER

For regular percussion power tools.

This adapter, mounted on an electric or pneumatic tool with a 1/2" square drive allows use of SDS drill bits. Furthermore, by using the special adapter RACSDSIH, designed for the insertion of an insert, the drill can be transformed into a screwdriver. The replacement of the SDS drill bit is easily done by means of a spring-loaded ring sliding on the spindle axis. In fact, gripping the ring, the weight of the drill itself opens the locking device. All the individual components of the chuck are made of treated steel.

ACCESSORIES

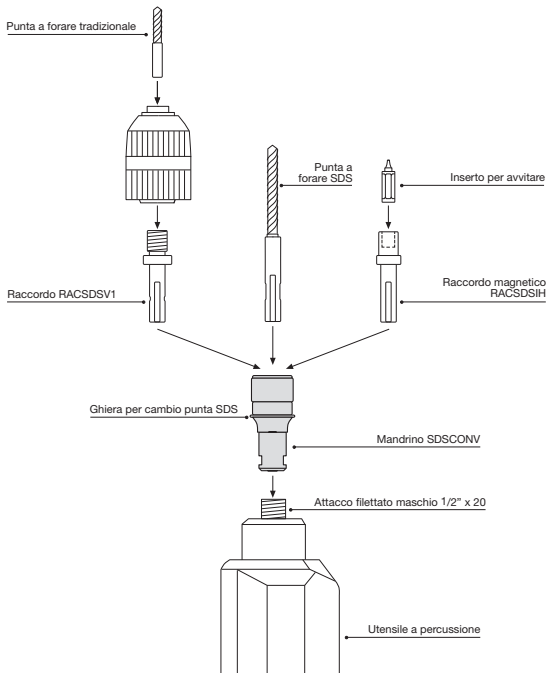

Model No	Power tools nose	A mm	B mm	C mm	D mm	Packaging style	Weight g
SDSCONV	1/2" x 20	22	28	30	58	Individual box	160
SDSCONVB	1/2" x 20	22	28	30	58	Blister card	160

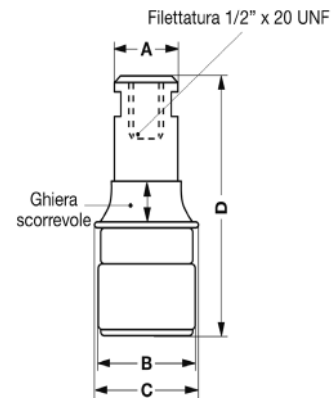

DRILLING AND SCREWING BITS

Quick change holder set.

Tool set includes 1/4" quick release chuck with 3/8" hexagon shank to be fitted in a power tool and three unique drill and drive bit combinations which enable easy and fast way to change tool for drilling hole and screwing.

ACCESSORIES

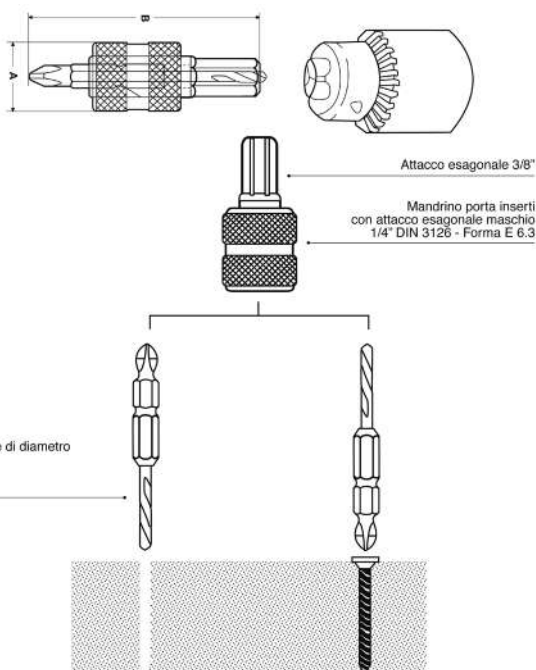

Model No	A mm	B mm	Packaging style	Weight g
DSTS	20,5	54	Blister card	90



RIVET CONVERTER

New Serie: Cast Aluminium body

Simply convert the standard cordless, electric, pneumatic, drill/drive into a blind rivet gun.

Accept 3/8" and 1/2" (10/13mm) drill chuck or 1/4" (6.35mm) hex recess.

Compatible with 12V, 14.4V and 18V cordless drill/drive and any reversible corded drill I drive.

Pull: Aluminium rivets: 2.4-4.8mm

Stainless steel rivets: 2.4-4.0mm

Comes complete 2.4-3.2-4.0-4.8mm (3/32"-1/8"-5/32"-3/16") 4 nosepieces.

Max rpm: 1000 rpm.

The shank of rivet is expelled when the drill is operated in the "reverse" mode.

If used with a combination impact drill, ensure that it is set to drilling mode.



Model No	Mount	Aluminium rivets size mm	Steel rivets size mm	Max speed	Packaging style	Weight g
RIVCONV	1/4" DIN 3126 FORM E 6,3	da 2,4 a 4,8	da 2,4 a 4,0	1000 rpm	Individual box	280



PARTICOLARI

- 1 Hexagon shank .” Din 3126 Form E 6.3
- 2 Housing: die cast aluminium
- 3 Nose piece: mm 2.4 – 3.2 – 4.0 – 4.8
- 4 Sight window: Blind rivet loading
- 5 Wrench with interchangeable noses

ACCESSORIES

CHUCK EXTENDER FOR PORTABLE DRILL

New series with die-cast aluminum body

The use of portable drills is often limited by their own body. This 300mm extension allows access to places where it is practically impossible with a portable drill.

The extension is equipped with an aluminum handle sliding on ball bearings to provide stability and direction to the drilling action.

The extension with a 9mm hexagonal shank for mounting on the drill can be equipped with:

Model PMK - key chuck Female thread 3/8"-24UNF, capacity 1.5-10 mm, standard key DIN S14, AH10F38R Porta's series.

Model PML - keyless chuck Female thread 3/8"-24UNF, capacity 1.5-10 mm, LD10F38R Porta's series.

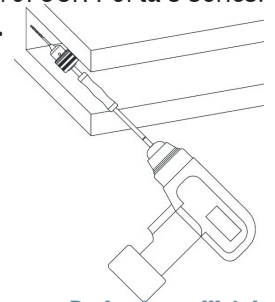

Model No	Mount	Drilling capacity mm	Key	Porta chuck	Packaging style	Weight g
PMK	3/8"-24UNF	1,5-10	DIN S14	AH10F38R	Bussolotto plastico	400
PML	3/8"-24UNF	1,5-10	-	LD10F38R	Bussolotto plastico	390

ACCESSORIES

FLEXIBLE BIT HOLDER FOR SCREWDRIVER

With ¼" hexagon Din 3126 E 6,3 driver for screwdrivers on one side and a quick change ¼" hexagon bit holder on the other side.

ACCESSORIES



Model No	Lenght mm	Max speed RMP	Max torque kgf/cm	Packaging style	Weight g
RACFLEX2	200	3000	165	Individual box	200
RACFLEX3	300	3000	135	Individual box	300
RACFLEX4	400	3000	135	Individual box	400

FLEXIBLE SHAFT WITH SPRING CHUCK

Available in two models: DIY and High Speed.

ACCESSORIES



Model No	Lenght mm	Max speed RMP	Max torque kgf/cm	Packaging style	Weight g
FS06DIY	1000	6000	Goodel 6mm	Individual box	700
FS06HS	1300	15000	Goodel 6mm	Individual box	900
FS06HS	1300	15000	Goodel 10mm	Individual box	940

QUICK CLAMPING NUT

TECHNICAL FEATURE: Suitable for grinding/cutting discs from 100 mm up to 230 mm and angle grinder power below 2400 W.

Easy tightening and release.

Available mount size: M14.

HOW TO INSTALL IT:

Place grinding/cutting wheel on spindle, making sure wheel is centered on flange.

Place the Quick Clamping Nut onto spindle, rotate clockwise and lock (2-4 Nm).

HOW TO REMOVE IT:

Grip the outer ring of the Quick Clamping Nut by hand and release it counterclockwise from the grinder spindle (2-4 Nm).

ACCESSORIES



Model No	Ø mm	Thickness mm	Female thr.	Packaging style	Weight g
QCNM14	46,5	13,4	M14	Individual box	110

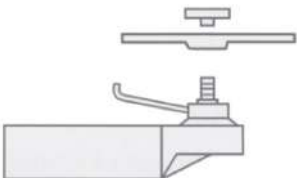

CHUCK ADAPTORS

ACCESSORIES



<i>Model No</i>	<i>Style</i>	<i>Description</i>	<i>Packaging style</i>	<i>Weight g</i>
RACSDSV1	BOSCH SDS+	To convert SDS and other direct drive systems to accept 1/2" x 20 female chuck for rotary only work Supplied complete with M6 left hand threaded retaining screw	Individual box	55
RACSDSV1B	BOSCH SDS+	To convert SDS and other direct drive systems to accept 1/2" x 20 female chuck for rotary only work Supplied complete with M6 left hand threaded retaining screw	Blister card	55
RACSDSIH magnetico	BOSCH SDS+	To convert SDS system to accept tools with 1/4" hexagon shanks for rotary rotation work	Bulk	50
RACSDSIHB magnetico	BOSCH SDS+	To convert SDS system to accept tools with 1/4" hexagon shanks for rotary rotation work	Blister card	50



<i>Model No</i>	<i>Description</i>	<i>Packaging style</i>	<i>Weight g</i>
RACX1	1/4" DIN 3126 Form E 6,3 hexagon shank with 3/8" x 24 threaded mount	Bulk	20



<i>Model No</i>	<i>Description</i>	<i>Packaging style</i>	<i>Weight g</i>
VSR10D5	M5 left hand thread spare screw total length 18 mm for use with 10 mm 3/8" x 24 threaded keyed chucks	Bulk	6
VSR10D6	M6 left hand thread spare screw total length 23 mm for use with 10 mm 1/2" x 20 threaded keyed chucks	Bulk	6
VSR13D6	M6 left hand thread spare screw total length 27 mm for use with SDS adaptors and 13 mm 1/2" x 20 threaded keyed chucks	Bulk	6
VSR13D6L	M6 left hand thread spare screw total length 32 mm for use with SDS adaptors and 13 mm 1/2" x 20 threaded keyed chucks	Bulk	6



<i>Model No</i>	<i>Description</i>	<i>Packaging style</i>	<i>Weight g</i>
RAC3812M	To convert 1/2" x 20 female to 3/8" x 24 male	Individual box	26
RAC3812MB	To convert 1/2" x 20 female to 3/8" x 24 male	Blister card	26
RAC3838M	To convert 3/8" x 24 female to 3/8" x 24 male	Individual box	19
RAC3838MB	To convert 3/8" x 24 female to 3/8" x 24 male	Blister card	19



<i>Model No</i>	<i>Description</i>	<i>Packaging style</i>	<i>Weight g</i>
RAC3812F	To convert 1/2" x 20 female to 3/8" x 24 female	Individual box	11
RAC3812FB	To convert 1/2" x 20 female to 3/8" x 24 female	Blister card	11

CHUCK ADAPTORS - cont.

ACCESSORIES



<i>Model No</i>	<i>Description</i>
RACX1SQ38B	1/4" hexagon adaptor to 3/8" square drive



<i>Model No</i>	<i>Description</i>
RACX1WBHB	1/4" wobble type adaptor <ul style="list-style-type: none"> • locked: straight position • unlocked: wobble position up to 25°



<i>Model No</i>	<i>Description</i>
RAC12SQ38B	Convert 1/2" x 20 thread to 3/8" square drive
RAC12SQ12B	Convert 1/2" x 20 thread to 6" square drive

QUICK RELEASE 1/4" HEXAGON BIT HOLDERS

ACCESSORIES



<i>Model No</i>	<i>Description</i>
RAC14HSQ14B	To be fitted on 1/4" square drive machine
RAC14HSQ38B	To be fitted on 3/8" square drive machine
RAC14HSQ12B	To be fitted on 1/2" square drive machine
RAC14HT38B	To be fitted on 3/8" x 24 threaded mount machine
RAC14HT12B	To be fitted on 1/2" x 20 threaded mount machine

MORSE TAPER ARBORS

With taper and threaded mounts, precision ground, hardened and tempered.

ARBORS

Model No	Morse taper DIN	Chuck mount	A mm	B mm	M mm	N mm	L mm	Packaging style	Weight g
C1B10	1	DIN B10	83	65,5	10,094	9,4	14,5	Individual box	55
C1B12	1	DIN B12	89	65,5	12,065	11,1	18,5	Individual box	65
C1B16	1	DIN B16	99	65,5	15,733	14,5	24	Individual box	90
C1B18	1	DIN B18	99	65,5	17,78	16,2	32	Individual box	110
C1J0	1	JACOBS 0	81	65,5	6,35	5,802	11,112	Individual box	50
C1J1	1	JACOBS 1	86	65,5	9,754	8,468	16,67	Individual box	50
C1J2	1	JACOBS 2	92	65,5	14,2	12,39	22,23	Individual box	60
C1J3	1	JACOBS 3	102	65,5	20,6	18,95	30,96	Individual box	60
C1J6	1	JACOBS 6	96	65,5	17,17	15,85	25,4	Individual box	60
C1J33	1	JACOBS 33	96	65,5	15,85	14,24	25,4	Individual box	60
C1F38	1	Thr. 3/8" x 24	83	65,5	—	—	14,3	Individual box	60
C1F12	1	Thr. 1/2" x 20	85	65,5	—	—	14,3	Individual box	60
C2B10	2	DIN B10	105	80	10,094	9,4	14,5	Individual box	130
C2B12	2	DIN B12	106	80	12,065	11,1	18,5	Individual box	135
C2B16	2	DIN B16	112	80	15,733	14,5	24	Individual box	160
C2B18	2	DIN B18	119	80	17,78	16,2	32	Individual box	180
C2B22	2	DIN B22	130	80	21,793	19,8	40,5	Individual box	245
C2J0	2	JACOBS 0	96	80	6,35	5,802	11,112	Individual box	125
C2J1	2	JACOBS 1	101	80	9,754	8,468	16,67	Individual box	130
C2J2	2	JACOBS 2	107	80	14,2	12,39	22,23	Individual box	160
C2J3	2	JACOBS 3	117	80	20,6	18,95	30,96	Individual box	200
C2J4	2	JACOBS 4	129	80	28,55	26,346	42,07	Individual box	210
C2J6	2	JACOBS 6	111	80	17,17	15,85	25,4	Individual box	165
C2J33	2	JACOBS 33	112	80	15,85	14,24	25,4	Individual box	160
C2F38	2	Thr. 3/8" x 24	96	80	—	—	14,3	Individual box	160
C2F12	2	Thr. 1/2" x 20	104	80	—	—	14,3	Individual box	165
C2F58	2	Thr. 5/8" x 16	117	80	—	—	17,5	Individual box	180
C2F34	2	Thr. 3/4" x 16	107	80	—	—	17,5	Individual box	190
C3B12	3	DIN B12	125	99	12,065	11,1	18,5	Individual box	280
C3B16	3	DIN B16	134	99	15,733	14,5	24	Individual box	310
C3B18	3	DIN B18	140	99	17,78	16,2	32	Individual box	320
C3B22	3	DIN B22	147	99	21,793	19,8	40,5	Individual box	390
C3B24	3	DIN B24	157	99	23,825	21,3	50,5	Individual box	440
C3J1	3	JACOBS 1	125	99	9,754	8,468	16,67	Individual box	290
C3J2	3	JACOBS 2	126	99	14,2	12,39	22,23	Individual box	310
C3J3	3	JACOBS 3	136	99	20,6	18,95	30,96	Individual box	350
C3J6	3	JACOBS 6	130	99	17,17	15,85	25,4	Individual box	310
C3J33	3	JACOBS 33	130	99	15,85	14,24	25,4	Individual box	310
C3J4	3	JACOBS 4	147	99	28,55	26,346	42,07	Individual box	330
C3F38	3	Thr. 3/8" x 24	114	99	—	—	14,3	Individual box	310
C3F12	3	Thr. 1/2" x 20	122	99	—	—	14,3	Individual box	320
C3F58	3	Thr. 5/8" x 16	126	99	—	—	17,5	Individual box	340



esterno Morse DIN 228

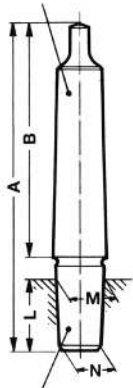

Cono del mandrino DIN 238 oppure JACOBS



Cono esterno Morse DIN 228

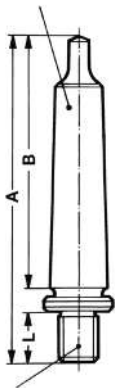

Filettato

MORSE TAPER ARBORS - cont

With taper and threaded mounts, precision ground, hardened and tempered.

ARBORS



Cono esterno Morse DIN 228

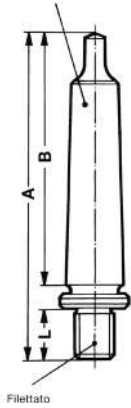

Model No	Morse taper DIN	Chuck mount	A mm	B mm	M mm	N mm	L mm	Packaging style	Weight g
C3F34	3	Thr. 3/4" x 16	126	99	—	—	17,5	Individual box	350
C4B16	4	DIN B16	156	124	15,733	14,5	24	Individual box	625
C4B18	4	DIN B18	164	124	17,78	16,2	32	Individual box	660
C4B22	4	DIN B22	176	124	21,793	19,8	40,5	Individual box	715
C4B24	4	DIN B24	186	124	23,825	21,3	50,5	Individual box	770
C4J2	4	JACOBS 2	153	124	14,2	12,39	22,23	Individual box	600
C4J3	4	JACOBS 3	162	124	20,6	18,95	30,96	Individual box	660
C4J4	4	JACOBS 4	173	124	28,55	26,346	42,07	Individual box	700
C4J5	4	JACOBS 5	179	124	35,89	33,422	47,625	Individual box	750
C4J6	4	JACOBS 6	156	124	17,17	15,85	25,4	Individual box	650
C4J33	4	JACOBS 33	156	124	15,85	14,24	25,4	Individual box	640
C5B16	5	DIN B16	198	156	15,733	14,5	24	Individual box	1600
C5B18	5	DIN B18	198	156	17,78	16,2	32	Individual box	1600
C5B22	5	DIN B22	207	156	21,793	19,8	40,5	Individual box	1650
C5B24	5	DIN B24	217	156	23,825	21,3	50,5	Individual box	1700
C5J3	5	JACOBS 3	198	156	20,6	18,95	30,96	Individual box	1600
C5J4	5	JACOBS 4	210	156	28,55	26,346	42,07	Individual box	1650
C5J5	5	JACOBS 5	216	156	35,89	33,422	47,625	Individual box	1700
C5J6	5	JACOBS 6	198	156	17,17	15,85	25,4	Individual box	1650

ISO TAPER ARBORS

Hardened and tempered according to DIN 2080.

ARBORS



Model No	Taper Iso	Chuck mount	Drawbolt thread	Packaging style	Weight g
ISO30J6	30	JACOBS 6	M12	Individual box	425
ISO30B12	30	DIN B12	M12	Individual box	420
ISO30B16	30	DIN B16	M12	Individual box	425
ISO40J6	40	JACOBS 6	M16	Individual box	970
ISO40B12	40	DIN B12	M16	Individual box	965
ISO40B16	40	DIN B16	M16	Individual box	970
ISO40B18	40	DIN B18	M16	Individual box	970
ISO50J6	50	JACOBS 6	M24	Individual box	2560
ISO50B16	50	DIN B16	M24	Individual box	2560
ISO50B18	50	DIN B18	M24	Individual box	2560

PARALLEL ARBORS

With Jacobs taper mounts.



ARBORS

Model No	A mm	B mm	Jacobs taper mount	Packaging style	Weight g
PA12J0	1/2"	64	0	Individual box	86
PA12J1	1/2"	64	1	Individual box	93
PA12J2	1/2"	64	2	Individual box	115
PA12J6	1/2"	64	6	Individual box	129
PA12J33	1/2"	64	33	Individual box	122
PA58J1	5/8"	64	1	Individual box	127
PA58J2	5/8"	64	2	Individual box	145
PA58J3	5/8"	64	3	Individual box	160
PA58J6	5/8"	64	6	Individual box	160
PA58J33	5/8"	64	33	Individual box	155
PA34J1	3/4"	72	1	Individual box	200
PA34J2	3/4"	72	2	Individual box	218
PA34J3	3/4"	72	3	Individual box	275
PA34J6	3/4"	72	6	Individual box	235
PA34J33	3/4"	72	33	Individual box	225
PA1J2	1"	74	2	Individual box	349
PA1J3	1"	74	3	Individual box	355
PA1J6	1"	74	6	Individual box	365
PA1J33	1"	74	33	Individual box	365

BRIDGEPORT R8 TAPER ADAPTORS

For chucks with DIN or Jacobs mount.

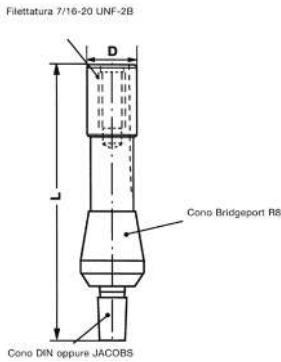

ARBORS

Model No	Taper	Mount	D mm	L mm	Drawbolt thread	Packaging style	Weight g
CR8B16	Bridgeport R8	DIN B16	24,1	135	7/16"-20	Individual box	425
CR8J2	Bridgeport R8	JACOBS 2	24,1	132	7/16"-20	Individual box	400
CR8J3	Bridgeport R8	JACOBS 3	24,1	141	7/16"-20	Individual box	460
CR8J6	Bridgeport R8	JACOBS 6	24,1	135	7/16"-20	Individual box	430
CR8J33	Bridgeport R8	JACOBS 33	24,1	135	7/16"-20	Individual box	420

BRIDGEPORT R8 TAPER ADAPTORS

For Morse taper.

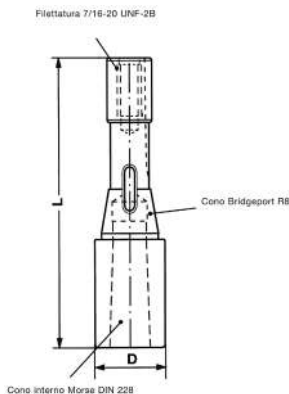

ARBORS

Model No	Taper	Morse taper	D mm	L mm	Drawbolt thread	Packaging style	Weight g
CR8MT1	Bridgeport R8	1	32	124	7/16"-20	Individual box	450
CR8MT2	Bridgeport R8	2	32	137	7/16"-20	Individual box	460
CR8MT3	Bridgeport R8	3	32	139	7/16"-20	Individual box	320

REDUCING SLEEVES

According to DIN 2185, hardened and tempered, precision ground internally and externally.



SLEEVES

Model No	Morse taper inside - outside		A mm	B mm	C mm	D mm	E mm	Packaging style	Weight g
B01	0	1	80	19	12,065	9,045	13	Individual box	30
B12	1	2	92	17	17,78	12,065	18,6	Individual box	95
B13	1	3	99	5	23,825	12,065	24,1	Individual box	250
B23	2	3	112	18	23,825	17,78	24,7	Individual box	190
B14	1	4	124	6,5	31,267	12,065	31,6	Individual box	550
B24	2	4	124	6,5	31,267	17,78	31,6	Individual box	480
B34	3	4	140	22,5	31,267	23,825	32,4	Individual box	360
B15	1	5	156	6,5	44,399	12,065	44,7	Individual box	1700
B25	2	5	156	6,5	44,399	17,78	44,7	Individual box	1520
B35	3	5	156	6,5	44,399	23,825	44,7	Individual box	1360
B45	4	5	171	21,5	44,399	31,267	45,5	Individual box	1020
B36	3	6	218	8	63,348	23,825	63,8	Individual box	5300
B46	4	6	218	8	63,348	31,267	63,8	Individual box	5010
B56	5	6	218	8	63,348	44,399	63,8	Individual box	4200

OIL TOUGHENED REDUCING SLEEVES

Externally precision ground with hardened tang.

SLEEVES

Cono esterno Morse DIN 228

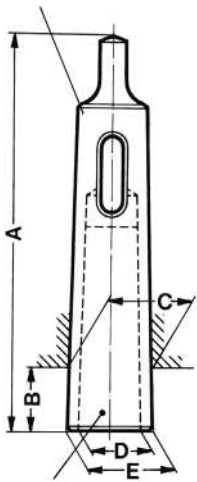

Cono interno Morse DIN 228

Model No	Morse taper inside - outside		A mm	B mm	C mm	D mm	E mm	Packaging style	Weight g
B010T	0	1	80	19	12,065	9,045	13	Individual box	30
B120T	1	2	92	17	17,78	12,065	18,6	Individual box	95
B130T	1	3	99	5	23,825	12,065	24,1	Individual box	250
B230T	2	3	112	18	23,825	17,78	24,7	Individual box	190
B140T	1	4	124	6,5	31,267	12,065	31,6	Individual box	550
B240T	2	4	124	6,5	31,267	17,78	31,6	Individual box	480
B340T	3	4	140	22,5	31,267	23,825	32,4	Individual box	360
B150T	1	5	156	6,5	44,399	12,065	44,7	Individual box	1700
B250T	2	5	156	6,5	44,399	17,78	44,7	Individual box	1520
B350T	3	5	156	6,5	44,399	23,825	44,7	Individual box	1360
B450T	4	5	171	21,5	44,399	31,267	45,5	Individual box	1020
B360T	3	6	218	8	63,348	23,825	63,8	Individual box	5300
B460T	4	6	218	8	63,348	31,267	63,8	Individual box	5010
B560T	5	6	218	8	63,348	44,399	63,8	Individual box	4200

REDUCING SLEEVES

With plain through hole, hardened and tempered, precision ground internally and externally.

SLEEVES

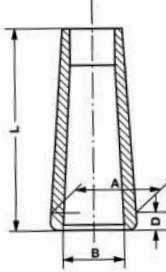

Model No	Morse taper inside - outside		A mm	B mm	C mm	D mm	E mm	Packaging style	Weight g
B12TH	1	2	50	4	17,78	12,065	50	Individual box	50
B13TH	1	3	55	4,5	23,825	12,065	140	Individual box	140
B23TH	2	3	60	4,5	23,825	17,78	90	Individual box	90
B14TH	1	4	65	5,3	31,267	12,065	320	Individual box	320
B24TH	2	4	70	5,3	31,267	17,78	260	Individual box	260
B34TH	3	4	75	5,3	31,267	23,825	170	Individual box	170
B25TH	2	5	80	6,3	44,4	17,78	770	Individual box	770
B35TH	3	5	90	6,3	44,4	23,825	740	Individual box	740
B45TH	4	5	95	6,3	44,4	31,267	560	Individual box	560
B36TH	3	6	110	7,9	63,38	23,825	2200	Individual box	2200
B46TH	4	6	120	7,9	63,38	31,267	2100	Individual box	2100
B56TH	5	6	125	7,9	63,38	44,4	1510	Individual box	1510

MORSE TAPER TURRET SOCKETS

Hardened case, ground internally and externally.

SLEEVES

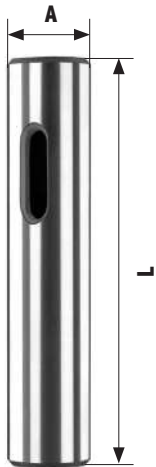

Cono interno
Morse DIN 228

Model No	Diameter A	Morse taper	L mm	Packaging style	Weight g
TS75MT1	3/4"	1	89	Individual box	280
TS1MT1	1"	1	89	Individual box	300
TS1MT2	1"	2	102	Individual box	
TS15MT1	1.1/2"	1	89	Individual box	600
TS15MT2	1.1/2"	2	102	Individual box	770
TS15MT3	1.1/2"	3	121	Individual box	820
TS15MT4	1.1/2"	4	153	Individual box	1150
TS2MT3	2"	3	121	Individual box	1500
TS2MT4	2"	4	153	Individual box	1800
TS2125MT3	2.1/8"	3	121	Individual box	1750
TS2125MT4	2.1/8"	4	153	Individual box	2100
TS2125MT5	2.1/8"	5	228	Individual box	2500
TS25MT3	2.1/2"	3	121	Individual box	2500
TS25MT4	2.1/2"	4	153	Individual box	2900
TS25MT5	2.1/2"	5	228	Individual box	4500
TSM20MT1	20 mm	1	89	Individual box	280
TSM25MT1	25 mm	1	89	Individual box	300
TSM25MT2	25 mm	2	102	Individual box	
TSM30MT3	30 mm	3	121	Individual box	750
TSM40MT2	40 mm	2	102	Individual box	770
TSM40MT3	40 mm	3	121	Individual box	820
TSM40MT4	40 mm	4	153	Individual box	1150
TSM50MT3	50 mm	3	121	Individual box	1750
TSM50MT4	50 mm	4	153	Individual box	2100

ISO TAPER TO MORSE TAPER ADAPTORS

According to DIN 2080.

Hardened and tempered, precision ground internally and externally.

SLEEVES



Model No	Iso taper outside	Iso taper inside	D mm	L mm	Drawbolt thread	Packaging style	Weight g
ISO30MT2	30	2	34	50	M12	Individual box	400
ISO30MT3	30	3	40	70	M12	Individual box	600
ISO40MT2	40	2	34	50	M16	Individual box	900
ISO40MT3	40	3	40	65	M16	Individual box	1000
ISO40MT4	40	4	50	95	M16	Individual box	1300
ISO50MT3	50	3	40	65	M24	Individual box	2800
ISO50MT4	50	4	50	70		Individual box	2800
ISO50MT5	50	5	65	105		Individual box	3200

EXTENSION SOCKETS

According to DIN 2187, hardened and tempered, precision ground internally and externally.

SOCKETS



Model No	Morse taper inside - outside	a1 mm	a2 mm	d1 mm	d2 mm	d3 mm	l1 mm	l2 mm	Packaging style	Weight g
BL11145	1 1	–	7	12,065	12,065	20	145	83	Individual box	190
BL12160	1 2	–	7	12,065	17,78	30	160	98	Individual box	250
BL21160	2 1	–	9	17,78	12,065	20	160	85	Individual box	340
BL22175	2 2	–	9	17,78	17,78	30	175	100	Individual box	400
BL23196	2 3	–	9	17,78	23,825	36	196	121	Individual box	550
BL31175	3 1	5	–	23,825	12,065	20	175	81	Individual box	400
BL32194	3 2	–	9	23,825	17,78	30	194	100	Individual box	840
BL33215	3 3	–	9	23,825	23,825	36	215	121	Individual box	1000
BL34240	3 4	–	9	23,825	31,267	48	240	146	Individual box	1300
BL41200	4 1	6,5	–	31,267	12,065	20	200	82,5	Individual box	800
BL42215	4 2	6,5	–	31,267	17,78	30	215	97,5	Individual box	850
BL43240	4 3	–	10,5	31,267	23,825	36	240	122,5	Individual box	1500
BL44265	4 4	–	10,5	31,267	31,267	48	265	147,5	Individual box	1900
BL45300	4 5	–	10,5	31,267	44,399	63	300	182,5	Individual box	2750
BL51232	5 1	6,5	–	44,399	12,065	20	232	82,5	Individual box	1600
BL52247	5 2	6,5	–	44,399	17,78	30	247	97,5	Individual box	1600
BL53268	5 3	6,5	–	44,399	23,825	36	268	118,5	Individual box	2840
BL54300	5 4	–	13,5	44,399	31,267	48	300	150,5	Individual box	3310
BL55335	5 5	–	13,5	44,399	44,399	63	335	185,5	Individual box	4200

OIL TOUGHENED EXTENSION SOCKETS

Externally precision ground with hardened tang.

SOCKETS

Model No	Morse taper outside - inside		a1 mm	a2 mm	d1 mm	d2 mm	d3 mm	l1 mm	l2 mm	Packaging style	Weight g
BL111450T	1	1	—	7	12,065	12,065	20	145	83	Individual box	190
BL121600T	1	2	—	7	12,065	17,78	30	160	98	Individual box	250
BL211600T	2	1	—	9	17,78	12,065	20	160	85	Individual box	340
BL221750T	2	2	—	9	17,78	17,78	30	175	100	Individual box	400
BL231960T	2	3	—	9	17,78	23,825	36	196	121	Individual box	550
BL311750T	3	1	5	—	23,825	12,065	20	175	81	Individual box	400
BL321940T	3	2	—	9	23,825	17,78	30	194	100	Individual box	840
BL332150T	3	3	—	9	23,825	23,825	36	215	121	Individual box	1000
BL342400T	3	4	—	9	—	31,267	48	240	146	Individual box	1300
BL412000T	4	1	6,5	—	31,267	12,065	20	200	82,5	Individual box	800
BL422150T	4	2	6,5	—	31,267	17,78	30	215	97,5	Individual box	850
BL432400T	4	3	—	10,5	31,267	23,825	36	240	122,5	Individual box	1500
BL442650T	4	4	—	10,5	31,267	31,267	48	265	147,5	Individual box	1900
BL453000T	4	5	—	10,5	31,267	44,399	63	300	182,5	Individual box	2750
BL512320T	5	1	6,5	—	44,399	12,065	20	232	82,5	Individual box	1600
BL522470T	5	2	6,5	—	44,399	17,78	30	247	97,5	Individual box	1600
BL532680T	5	3	6,5	—	44,399	23,825	36	268	118,5	Individual box	2840
BL543000T	5	4	—	13,5	44,399	31,267	48	300	150,5	Individual box	3310
BL553350T	5	5	—	13,5	44,399	44,399	63	335	185,5	Individual box	4200

Cono esterno Morse DIN 228

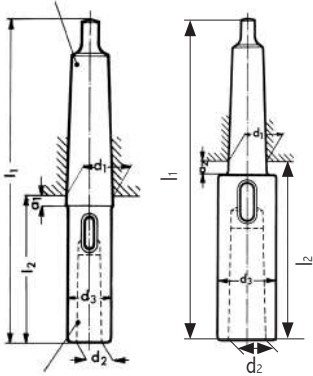

OIL TOUGHENED LONG PATTERN EXTENSION SOCKETS

Externally precision ground with hardened tang.

Model No	Morse taper outside - inside		a1 mm	a2 mm	d1 mm	d2 mm	d3 mm	l1 mm	l2 mm	Packaging style	Weight g
BL112000T	1	1	—	7	12,065	12,065	20	200	138	Individual box	250
BL112500T	1	1	—	7	12,065	12,065	20	250	188	Individual box	375
BL113000T	1	1	—	7	12,065	12,065	20	300	238	Individual box	500
BL113500T	1	1	—	7	12,065	12,065	20	350	288	Individual box	625
BL114000T	1	1	—	7	12,065	12,065	20	400	338	Individual box	750
BL114500T	1	1	—	7	12,065	12,065	20	450	388	Individual box	875
BL115000T	1	1	—	7	12,065	12,065	20	500	438	Individual box	1000
BL222000T	2	2	—	9	17,78	17,78	25	200	125	Individual box	430
BL222500T	2	2	—	9	17,78	17,78	25	250	175	Individual box	625
BL223000T	2	2	—	9	17,78	17,78	25	300	225	Individual box	820
BL223500T	2	2	—	9	17,78	17,78	25	350	275	Individual box	1015
BL224000T	2	2	—	9	17,78	17,78	25	400	325	Individual box	1200
BL224500T	2	2	—	9	17,78	17,78	25	450	375	Individual box	1400
BL225000T	2	2	—	9	17,78	17,78	25	500	425	Individual box	1600
BL226000T	2	2	—	9	17,78	17,78	25	600	525	Individual box	1800
BL332500T	3	3	—	9	23,825	23,825	32	250	156	Individual box	1000
BL333000T	3	3	—	9	23,825	23,825	32	300	206	Individual box	1300
BL333500T	3	3	—	9	23,825	23,825	32	350	256	Individual box	1550
BL334000T	3	3	—	9	23,825	23,825	32	400	306	Individual box	1850
BL334500T	3	3	—	9	23,825	23,825	32	450	356	Individual box	2100
BL335000T	3	3	—	9	23,825	23,825	32	500	406	Individual box	2400
BL336000T	3	3	—	9	23,825	23,825	32	600	506	Individual box	2700
BL443000T	4	4	—	10,5	31,267	31,267	40	300	182,5	Individual box	1650
BL443500T	4	4	—	10,5	31,267	31,267	40	350	232,5	Individual box	2150
BL444000T	4	4	—	10,5	31,267	31,267	40	400	282,5	Individual box	2650
BL444500T	4	4	—	10,5	31,267	31,267	40	450	332,5	Individual box	3100
BL445000T	4	4	—	10,5	31,267	31,267	40	500	382,5	Individual box	3600
BL446000T	4	4	—	10,5	31,267	31,267	40	600	482,5	Individual box	4200

Cono esterno Morse DIN 228

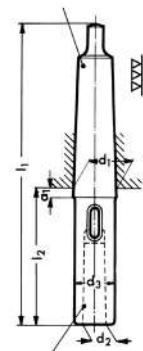

Cono interno Morse DIN 228



LATHE (DEAD) CENTRES PRECISION GROUND

Hardened and tempered according to DIN 806.

LATHE CENTRES



CARBON STEEL FULL POINT 60°

Model No	Morse taper	A mm	B mm	E mm	F mm	Packaging style	Weight g
CFR1	1	12,2	80	7,6	22	Individual box	55
CFR2	2	18	100	11	30	Individual box	145
CFR3	3	24,1	125	15	38	Individual box	310
CFR4	4	31,6	160	21	50	Individual box	740
CFR5	5	44,7	200	29,4	63	Individual box	1800
CFR6	6	63,8	270	42	79	Individual box	4800



CARBON STEEL HALF POINT 60°

Model No	Morse taper	A mm	B mm	E mm	F mm	Packaging style	Weight g
CFR1	1	12,2	80	7,6	22	Individual box	55
CFR2	2	18	100	11	30	Individual box	145
CFR3	3	24,1	125	15	38	Individual box	310
CFR4	4	31,6	160	21	50	Individual box	740
CFR5	5	44,7	200	29,4	63	Individual box	1800
CFR6	6	63,8	270	42	79	Individual box	4800



CARBIDE TIPPED FULL POINT 60°

Model No	Morse taper	A mm	B mm	D mm	Packaging style	Weight g
CFW1	1	12,2	80	7	Individual box	60
CFW2	2	18	100	7	Individual box	150
CFW3	3	24,1	125	11	Individual box	340
CFW4	4	31,6	160	14	Individual box	790
CFW5	5	44,7	200	18	Individual box	1920
CFW6	6	63,8	270	18	Individual box	5200



CARBIDE TIPPED HALF POINT 60°

Model No	Morse taper	A mm	B mm	D mm	E mm	F mm	Packaging style	Weight g
CFWR1	1	12,2	80	7	7,6	22	Individual box	55
CFWR2	2	18	100	7	11	30	Individual box	145
CFWR3	3	24,1	125	11	15	38	Individual box	310
CFWR4	4	31,6	160	14	21	50	Individual box	740
CFWR5	5	44,7	200	18	29,4	63	Individual box	1800
CFWR6	6	63,8	270	18	42	79	Individual box	4800

LATHE CENTRES

with draw off nut according to DIN 807.

LATHE CENTRES

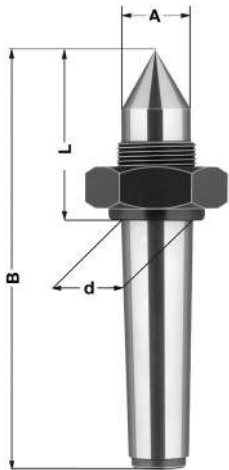

STANDARD POINT COMPLETELY HARDENED AND GROUND

Model No	Morse taper	A filettatura	B mm	d mm	L mm	Packaging style	Weight g
CDN1	1	M16x1.5	90	12,065	36,5	Individual box	140
CDN2	2	M22x1.5	112	17,78	48	Individual box	300
CDN3	3	M27x1.5	138	23,825	57	Individual box	580
CDN4	4	M36x1.5	175	31,267	72,5	Individual box	800
CDN5	5	M48x1.5	217	44,399	87,5	Individual box	2900
CDN6	6	M68x1.5	290	63,348	108	Individual box	7200

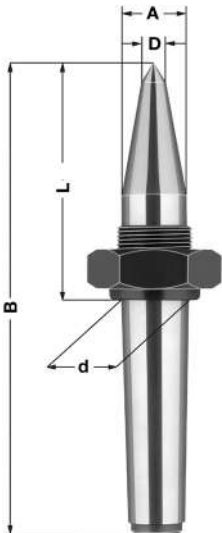

EXTENDED POINT COMPLETELY HARDENED AND GROUND

Model No	Morse taper	A filettatura	B mm	D mm	d mm	L mm	Packaging style	Weight g
CCDN1	1	M16x1.5	93	5	12,065	36,5	Individual box	170
CCDN2	2	M22x1.5	118	10	17,78	54	Individual box	300
CCDN3	3	M27x1.5	148	10	23,825	67	Individual box	600
CCDN4	4	M36x1.5	186,5	14	31,267	84	Individual box	1285
CCDN5	5	M48x1.5	242	16	44,399	112	Individual box	3000
CCDN6	6	M68x1.5	330	20	63,348	148	Individual box	7900

SPARE DRAW OFF NUTS

Model No	Morse taper	Thread
DNM16	1	M16x1.5
DNM22	2	M22x1.5
DNM27	3	M27x1.5
DNM36	4	M36x1.5
DNM48	5	M48x1.5
DNM68	6	M68x1.5

GENERAL PURPOSE



Model No	Morse taper	D mm	d mm	d1 mm	L mm	A mm	B mm	C mm	Max workpiece weight kg	Max speed r.p.m.	Max runout mm	Packaging style	Weight g
M1	1	34	14	12,06	51	16	30	105	80	3800	0,008	Individual box	200
M2	2	45	20	17,78	75	25	40	139	180	3800	0,008	Individual box	550
M3	3	50	23	23,82	90	34	48	172	270	3500	0,008	Individual box	970
M4	4	62	28	31,26	99	35	52	202	550	3500	0,008	Individual box	1550
M5	5	75	38	44,39	130	52	65	259	1000	3000	0,012	Individual box	3200
M6	6	96	50	63,34	156	65	82	338	1500	2600	0,015	Individual box	7500

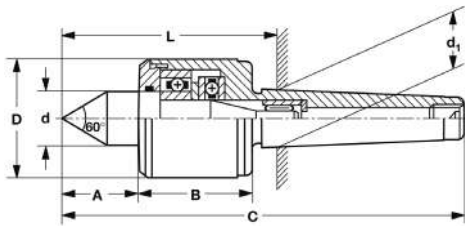

REDUCED BODY DIAMETER



Model No	Morse taper	D mm	d mm	d1 mm	L mm	A mm	B mm	C mm	Max workpiece weight kg	Max speed r.p.m.	Max runout mm	Packaging style	Weight g
MR2	2	32	15	17,78	62	20	37	128	200	6000	0,005	Individual box	300
MR3	3	34	15	23,82	63	20	38	141	400	6000	0,005	Individual box	500
MR4	4	42	20	31,26	76	26	42	180	800	6000	0,005	Individual box	1000
MR5	5	58	30	44,39	105	35	62	238	1200	4000	0,008	Individual box	2500

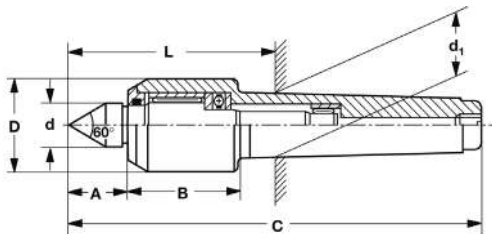

WOODWORKING



Model No	Morse taper	D mm	d mm	d1 mm	L mm	A mm	B mm	C mm	Max workpiece weight kg	Max speed r.p.m.	Max runout mm	Packaging style	Weight g
MW2	2	32	15	17,78	56,8	20	28,1	119	4	6200	0,03	Individual box	280

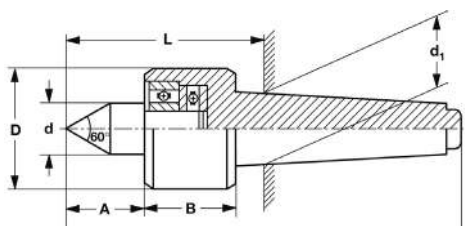

EXTENDED POINT FOR COPY TURNING MACHINES



Model No	Morse taper	D mm	d mm	d1 mm	L mm	A mm	B mm	C mm	E mm	Max workpiece weight kg	Max speed r.p.m.	Max runout mm	Packaging style	Weight g
MC3	3	50	23	23,82	90	35	48	171	11	270	4200	0,008	Individual box	970
MC4	4	60	25	31,26	101	39	52	205	14	550	3800	0,008	Individual box	1550
MC5	5	75	38	44,39	131	53	65	260	20	1000	3000	0,012	Individual box	3200

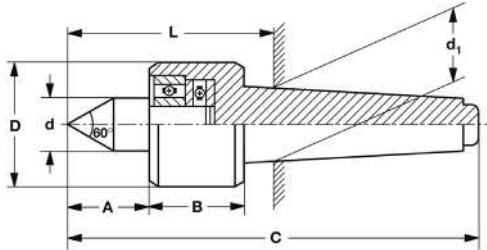

REDUCED BODY DIAMETER EXTENDED POINT FOR COPY TURNING MACHINES



Model No	Morse taper	D mm	d mm	d1 mm	L mm	A mm	B mm	C mm	E mm	Max workpiece weight kg	Max speed r.p.m.	Max runout mm	Packaging style	Weight g
MRC2	2	32	15	17,78	71	29	37	137	8	150	6000	0,005	Individual box	300
MRC3	3	34	15	23,82	73	30	38	151	8	300	6000	0,005	Individual box	500
MRC4	4	42	20	31,26	86	36	42	190	10	700	6000	0,005	Individual box	1000
MRC5	5	58	30	44,39	116	46	62	249	12	1000	4000	0,01	Individual box	2500

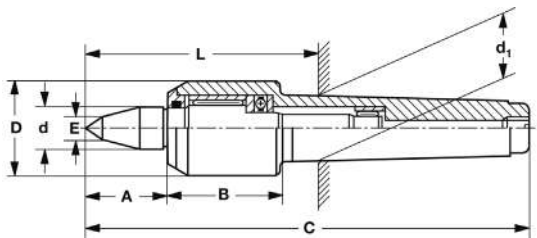

TECHNICAL INFORMATION

CHUCK TAPER MOUNT DIMENSIONS ACCORDING TO DIN 238 AND JACOBS NORMS

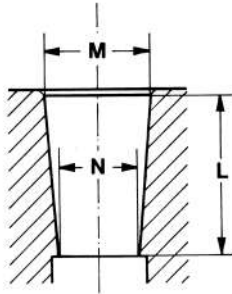

Norm	Chuck taper mount	M mm	N mm	L mm
DIN 238	B6	6,35	5,85	10
DIN 238	B10	10,094	9,4	14,5
DIN 238	B12	12,065	11,1	18,5
DIN 238	B16	15,733	14,5	24
DIN 238	B18	17,78	16,2	32
DIN 238	B22	21,793	19,8	40,5
DIN 238	B24	23,825	21,3	50,5
JACOBS	J0	6,35	5,803	11,11
JACOBS	J1	9,754	8,468	16,67
JACOBS	J2	14,2	12,39	22,23
JACOBS	J2 short	13,94	12,39	19,05
JACOBS	J33	15,85	14,24	25,4
JACOBS	J6	17,17	15,85	25,4
JACOBS	J3	20,6	18,95	30,96
JACOBS	J4	28,55	26,35	42,07

CHUCK THREADED MOUNT DIMENSIONS

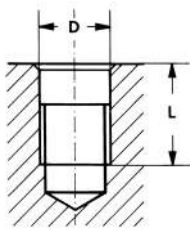

Threaded mount	Class	D mm	Passo mm	L mm
3/8" x 24 UNF	3B	9,525	1,058	14,5
1/2" x 20 UNF	3B	12,7	1,27	16
5/8" x 16 UN	3B	15,875	1,588	19
3/4" x 16 UNF	3B	19,05	1,588	19
M14 x 2	MA	14	2	19
M18 x 2.5	MA	18	2,5	19

MORSE TAPER DIMENSIONS ACCORDING TO DIN 228

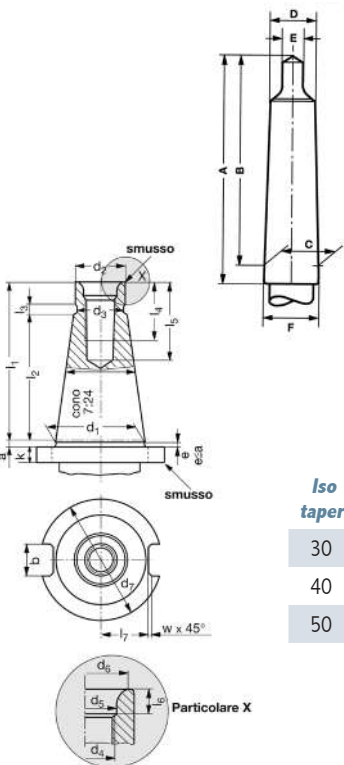

Morse taper	A mm	B mm	C mm	D mm	E mm	F mm	Taper %
0	59,5	56,5	9,045	6,1	3,9	9,2	5,205
1	65,5	62	12,065	9	5,2	12,2	4,988
2	80	75	17,78	14	6,3	18	4,995
3	99	94	23,825	19,1	7,9	24,1	5,02
4	124	117,5	31,267	25,2	11,9	31,6	5,194
5	156	149,5	44,399	36,5	15,9	44,7	5,263
6	218	210	63,348	52,4	19	63,8	5,214

ISO TAPER DIMENSIONS ACCORDING TO DIN 2080

Iso taper	a mm	b mm	d1 mm	d2 mm	d3 mm	d4 mm	d5 mm	d6 mm	d7 mm	k mm	l1 mm	l2 mm	l3 mm	l4 mm	l5 mm	l6 mm	l7 mm	w mm
30	1,6	16,1	31,75	17,11	16,5	M12	13	16	50	8	68,4	48,4	3	24	33,5	5,5	16,2	1,6
40	1,6	16,1	44,45	25	24	M16	17	21,5	63	10	93,4	65,4	5	32	42,5	8,2	22,5	1,6
50	3,2	25,7	69,85	39,3	38	M24	26	32	97,5	12	126,8	101,8	8	47	61,5	11,5	35,3	2

NOTE



Porta

PORTA SRL
VIA SOMMARIVA 33/12
10022 CARMAGNOLA (TO)

T. +39 011 9710018
E. PORTA @PORTACHUCKS.COM
WWW.PORTACHUCKS.COM